

# 11

## *Multilevel Ground-Water Monitoring*

Murray Einarson

### CONTENTS

Introduction .....	808
Why Three-Dimensional Plume Delineation is Necessary .....	812
Measurement of Vertical Hydraulic Heads .....	814
One Time Sampling versus Permanent Multilevel Monitoring Devices .....	814
Where You Monitor is as Important as How You Monitor .....	816
Options for Multilevel Ground-Water Monitoring .....	819
Multilevel Sampling within Single-Interval Monitoring Wells .....	819
Multiple Diffusion Samplers Installed inside Single-Interval Monitoring Wells .....	819
Diffusion Multilevel System .....	820
Passive Diffusion Bag Samplers .....	821
Active Collection of Samples from Multiple Depths within a Single-Interval Well Using Grab Samplers or Depth-Discrete Pumping .....	821
Grab or Thief Samplers .....	822
Collecting Depth-Discrete Samples by Pumping from Different Depths in Well Screens .....	822
Nested Wells (Multiple Tubes or Casings in a Single Borehole) .....	823
Bundle Wells Installed in Collapsing Sand Formations .....	824
Nested Wells Installed with Seals between Monitored Zones .....	824
Well Clusters (One Well per Borehole) .....	829
Dedicated Multilevel Ground-Water Monitoring Systems .....	830
Drilling and Installation Considerations .....	833
Installations in Open Boreholes .....	833
Installations in Unconsolidated Sedimentary Deposits .....	833
Minimizing Cross-Contamination .....	836
Development of Multilevel Wells .....	836
Westbay MP System .....	837
Solinst Waterloo System .....	839
Solinst CMT System .....	841
Water FLUTe System .....	843
References .....	845

---

## Introduction

One of the most important discoveries made during the last four decades of ground-water research is that the distribution of dissolved contaminants in the subsurface is spatially complex, especially in the vertical dimension. This is due to a number of factors, including the labyrinthine distribution of residual contamination in most non-aqueous-phase liquid (NAPL) source zones, geologic heterogeneity, and mixing mechanisms (e.g., mechanical mixing and molecular diffusion), that are relatively weak in most ground-water flow systems (National Research Council, 1994). This discovery was made possible by the use of multilevel sampling devices that facilitated the collection of discrete ground-water samples from up to 20 different depths in a single borehole (Cherry et al., 1981; MacFarlane et al., 1983; Reinhard et al., 1984; Smith et al., 1987; Robertson et al., 1991; van der Kamp et al., 1994).

Assessment and monitoring of ground-water contamination at nonresearch sites in North America began in earnest in the late 1980s following passage of the Resource Conservation and Recovery Act (RCRA) and the Comprehensive Environmental Response, Compensation, and Liability Act (CERCLA), commonly known as "Superfund." At nonresearch sites, however, environmental consultants — following early guidance from U.S. EPA and some State regulatory agencies — installed single-interval monitoring wells with screen lengths ranging from 10 to 30 ft to collect ground-water samples. Since then, the use of such wells (referred to in this chapter as "conventional" monitoring wells) to collect ground-water samples for chemical analysis has become standard practice in North America. Analysis of samples from single-interval, conventional monitoring wells, however, has led to a common misconception by ground-water practitioners that contaminant plumes are vertically homogeneous because, lacking data to the contrary, most assume that the concentrations of solutes measured in the samples are representative of concentrations within the entire portion of the aquifers screened by the wells.

In the late 1980s, ground-water researchers began to study the biases and apparent plume distortion caused by conventional, single-interval monitoring wells (see Sidebar). The studies show that conventional monitoring wells yield composite samples that mask the true vertical distribution of dissolved contaminants in the aquifer. Further, the composite samples are strongly biased by the position and length of the well screens, the pumping rate during sampling, and ambient vertical flow in the well (see Sidebar). Continued industry reliance on conventional monitoring wells for site assessment and monitoring has prolonged the misconception that the distribution of dissolved contaminants in the subsurface is more homogeneous than it really is. This can have serious consequences for health risk assessments and the performance of *in situ* remediation systems, as discussed later in this chapter.

The bias caused by compositing in monitoring wells is shown conceptually in Figure 11.1. In Figure 11.1a, several monitoring wells are shown. The well labeled "L" is a single-interval well with a relatively long screen. Wells labeled "M" make up a cluster of three wells completed at different depths in the aquifer. Well "N" is a multilevel monitoring well that yields ground-water samples from seven discrete depths. In Figure 11.1b, the concentrations of a hypothetical dissolved contaminant in the aquifer are depicted in a heavy dashed line. Well "L" (the well with a relatively long screen) yields a sample that is a mixture of water containing high concentrations of the contaminant (entering the well from the upper part of the well screen) and water that has lower concentrations of the solute (entering the well from deeper portions of the aquifer). The sample from well

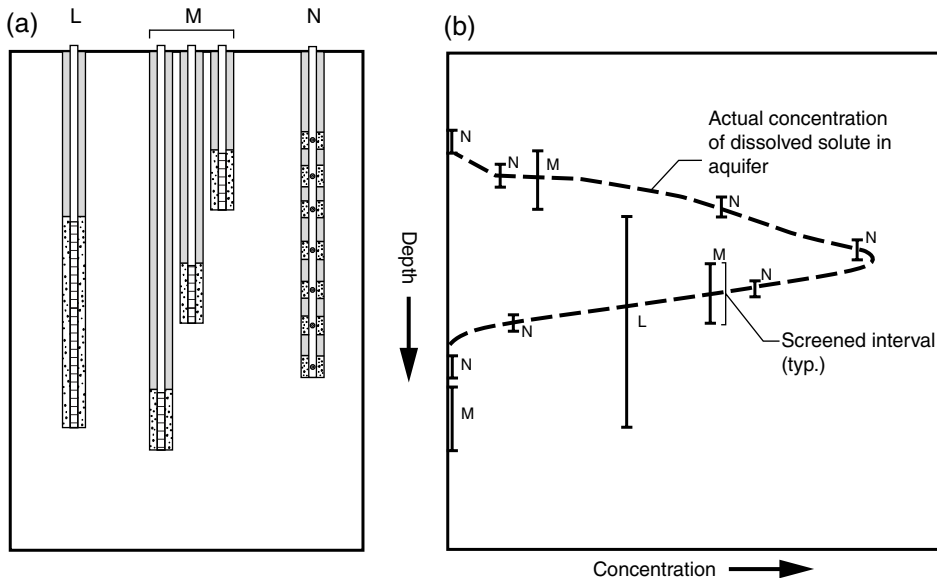

**FIGURE 11.1**

Effect of well screen length on sample concentrations. (a) Three types of monitoring well completions – single-zone, long-screen well (well “L”); cluster of three wells completed to different depths (wells “M”); and multilevel well (well “N”). (b) Heavy dashed line shows actual concentration of a dissolved solute in the aquifer. Single-zone, long-screen well (well “L”) yields a sample that is a mixture of high concentrations of the solute entering the upper portion of the well screens and low concentrations entering the lower portion of the well. Multilevel monitoring well (well “N”) yields samples that most closely represent the true distribution of the dissolved solute in the aquifer. See text for further discussion. (From John Cherry. With permission.)

“L” is therefore a composite that: (1) understates the peak concentrations in the portion of the aquifer screened by the upper part of the well and (2) overstates the presumed depth of dissolved-phase contamination in the aquifer. The cluster of three wells with shorter well screens (well cluster “M”) yields samples that more closely reflect the actual distribution of the dissolved-phase contaminants in the aquifer than the sample from the single long-screened well. The multilevel well (well “N”) provides samples that most closely resemble the actual distribution of the dissolved-phase contaminants in the aquifer.

A real-life example of the bias caused by sample compositing can be seen in data collected from a multilevel monitoring well that was installed in Santa Monica, CA to monitor a dissolved plume of methyl tert butyl ether (MTBE). The multilevel well was located within 20 ft of a pair of 4-in. diameter conventional monitoring wells (Wells MW-14 and MW-16) in order to compare the concentrations of MTBE in water samples collected from the multilevel well with samples collected from the conventional wells (Einarson and Cherry, 2002). A summary of the stratigraphy and construction of the CMT well and the nearby conventional monitoring wells is shown in Figure 11.3. A graph of MTBE concentrations versus depth for all three wells is shown on the right of the figure. Comparison of the MTBE concentrations measured in samples from the multilevel well with data from the conventional wells provides an example of contaminant mixing in monitoring wells described earlier. It is clear from the figure that the conventional wells yield ground-water samples that are a composite of ground water within the vertical interval of the aquifer screened by the wells. Analysis of a sample from Zone 3 of the multilevel well shows that MTBE is present in the aquifer at concentrations as high as 5300  $\mu\text{g}/\text{l}$ . However, the concentration of MTBE measured in samples from the

### **Sample Biases and Cross-Contamination Associated with Conventional Single-Interval Monitoring Wells**

Several field, laboratory, and modeling studies have been performed in the last 15 yr to evaluate whether ground-water samples collected from conventional, single-interval monitoring wells (i.e., wells having a single-screened interval ranging from 10 to 30 ft long) accurately reflect the concentration of dissolved contaminants in the portion of the aquifer screened by the wells (Robbins, 1989; Martin-Hayden et al., 1991; Robbins and Martin-Hayden, 1991; Gibs et al., 1993; Akindunni et al., 1995; Chiang et al., 1995; Conant Jr. et al., 1995; Church and Granato, 1996; Reilly and Gibs, 1996; Martin-Hayden and Robbins, 1997; Reilly and LeBlanc, 1998; Hutchins and Acree, 2000; Martin-Hayden, 2000a; 2000b; Elci et al., 2001). From these studies, it is clear that water samples collected from conventional monitoring wells are actually blended or composite samples. If the dissolved contaminants are stratified within the aquifer, which, based on detailed vertical ground-water sampling at several field research sites, appears to be the rule rather than the exception, compositing in long-screened wells during sampling results in underestimation of the maximum concentrations present in the aquifer. Robbins (1989) calculated that the negative bias caused by in-well blending could be up to an order of magnitude. Gibs et al. (1993) performed a field study and concluded that the contaminant concentration in a vertically averaged sample would be 28% of the maximum concentration in the aquifer. Moreover, if the wells partially penetrate the aquifer, an additional bias is introduced due to ground water (either clean or contaminated) flowing into the well from above and below the well screens (Akindunni et al., 1995; Conant Jr. et al., 1995; Chiang et al., 1995). Further, modeling performed by Martin-Hayden and Robbins (1997) showed that vertical concentration averaging in monitoring wells can result in significant over-prediction of contaminant retardation factors and apparent decay constants.

Other researchers have focused on the biases caused by ambient vertical flow of ground water in wells when they are not being pumped (McIlvride and Rector, 1988; Reilly et al., 1989; Church and Granato, 1996; Hutchins and Acree, 2000; Elci et al., 2001; Elci et al., 2003). In areas with vertical hydraulic gradients, installation of a monitoring well may set up a local vertical flow system because of the natural vertical hydraulic gradient at the well location. The well then acts as a "short circuit" along this gradient, with the resulting flow in the wellbore often of sufficient magnitude to compromise the integrity of any samples collected from the well (Elci et al., 2001). Reilly et al. (1989) concluded that ambient vertical flow renders long-screen wells "almost useless." They also noted that borehole flow and transport of contaminants in long-screen wells may contaminate parts of the aquifer that would not otherwise become contaminated in the absence of a long-screen well. Church and Granato (1996) concluded that "long-screen wells will fail even in a relatively ideal setting, and therefore, cannot be relied upon for accurate measurements of water-table levels, collection of water-quality samples, or fluid-conductance logging." Hutchins and Acree (2000) found that ambient vertical flow of less contaminated ground water into a monitoring well with only 10 ft of well screen caused a significant negative bias that could not be negated by purging the well prior to sampling. Elci et al. (2001) used a numerical model to simulate ambient vertical flow in a fully screened well at the Savannah River Site near Aiken, SC (see Figure 11.2). The site has an upward hydraulic gradient, so flow within the well was upward. Tracer transport simulations showed how a contaminant located initially in a lower portion of the aquifer ("A" in Figure 11.2) was transported into the upper portion and diluted throughout the entire well by inflowing water. Even after full purging, samples

from such a well will yield misleading and ambiguous data concerning solute concentrations, location of a contaminant source, and plume geometry (Elci et al., 2001). Not only are the samples from the well biased, but also, as shown in the figure, the well itself has created a vertical conduit that has cross-contaminated the aquifer. There are also other significant implications of the ambient flow condition depicted in the Figure 11.2. Imagine that clean water and not a tracer or contaminant plume entered the well at location "A" in the figure. Clean water would therefore be flowing up the wellbore and would be discharging in the upper portion of the aquifer. What if in this scenario the source of contamination was higher up in the aquifer near the location of "B" in the figure (e.g., a plume emanating from a fuel release site)? The plume emanating from source "B" would actually flow *around* the dome of clean water being discharged from the monitoring well and would completely escape detection. Samples collected from the well, even samples carefully collected with depth-discrete bailers or diffusion bag samplers, would be sampling clean water entering the well from the bottom of the well screen. Elci et al. (2001) point out that ambient ground-water flow in monitoring wells is not atypical. They report that significant ambient vertical flow occurred in 73% of 142 wells that had been tested using sensitive borehole flowmeters. It is for these reasons that Elci et al. (2001) conclude that the "use of long-screened monitoring wells should be phased out unless an appropriate multilevel sampling device prevents vertical flow."

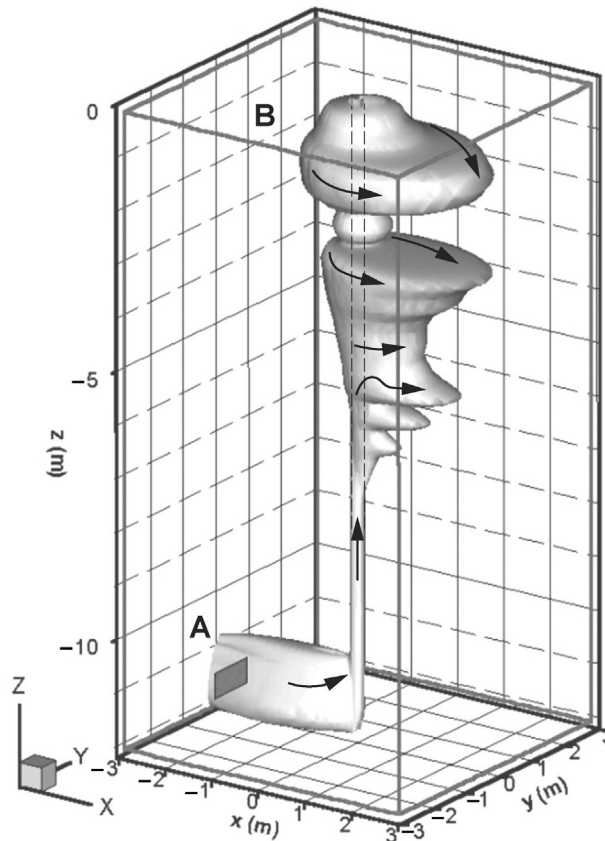

**FIGURE 11.2**

Simulation of the hydraulic capture of a deep contaminant plume by an unpumped, fully screened monitoring well and transport up and out of the wellbore under ambient flow conditions. See Sidebar for further discussion. (Adapted from Elci et al. [2001]. With permission.)

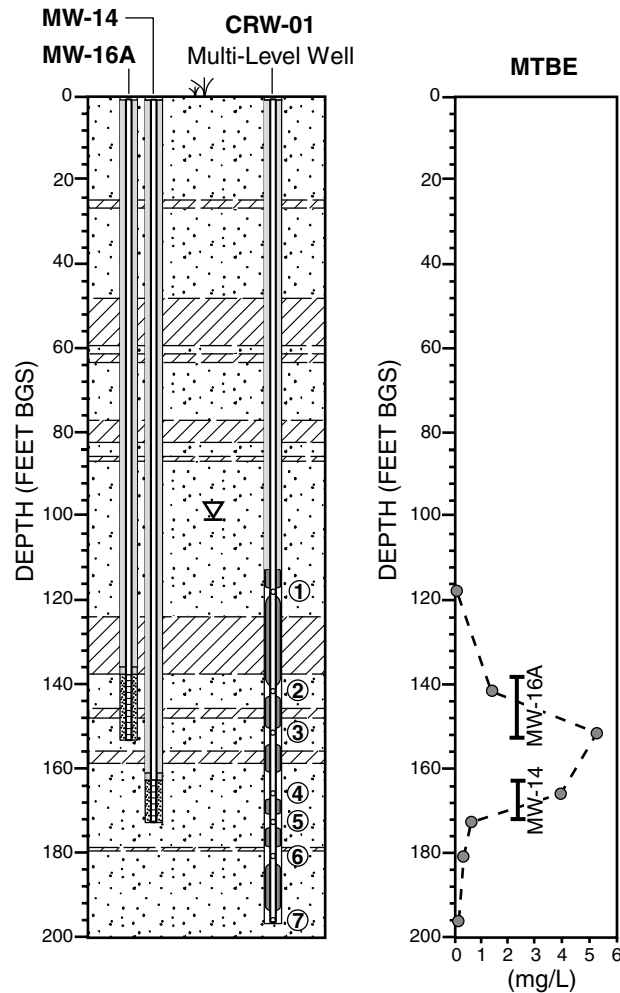

**FIGURE 11.3**

Construction details and MTBE concentration profile from a multilevel well plotted next to data from two nearby conventional monitoring wells, Santa Monica, CA. (Adapted from Einarson and Cherry [2002]. With permission.)

conventional wells is much lower (approximately  $2300 \mu\text{g/l}$ ) because relatively clean water (entering the upper portion of MW-16's well screen and the lower portion of MW-14's well screen) mixes with the water containing high concentrations of MTBE when these wells are pumped.

### Why Three-Dimensional Plume Delineation is Necessary

Defining the true distribution of dissolved contaminants is arguably the most important part of an environmental site assessment. The risk to downgradient receptors is commonly estimated by calculating the future concentration at the receptor's location. The calculations are typically performed by estimating (using analytical or numerical equations) the attenuation of the contaminant from some starting concentration near the release site. If the starting concentration is underestimated (e.g., by using results obtained from

composite samples from long-screened monitoring wells), the risk to the downgradient receptor (typically a water-supply well) may be underestimated. Similar arguments can be made for predictions of the risks associated with exposures to vapors emanating from residual contamination near source areas or flowing in shallow contaminant plumes. Vapor migration is dominated by molecular diffusion. Because diffusion is driven by concentration gradients, underestimating the peak contaminant concentrations in the subsurface will result in an underestimation of the risk posed to the vapor receptors. However, in other cases, data from long-screened wells can *overestimate* the risk to vapor receptors. For example, ground-water recharge at a site may create a layer of clean water atop a deeper dissolved contaminant plume. The layer of clean water may constitute an effective diffusion barrier that impedes the upward migration of volatile contaminants from the dissolved plume (Rivett, 1995). The layer of clean ground water overlying the contaminant plume could only be identified if multilevel ground-water monitoring wells or direct-push (DP) samplers were used. The same layer of clean ground water would be completely missed by collecting a composite ground-water sample from a single-zone well screened over the same depth interval.

Finally, effective remediation systems can be designed only if the concentration and distribution of the contaminants are accurately defined. This is especially true for passive *in situ* remediation technologies, such as permeable reactive barriers (PRBs). PRBs treat contaminants *in situ* by trapping or degrading the contaminants as they flow through them under natural gradient conditions. Complete removal or treatment of the contaminants requires sufficient residence time within the PRB. In all PRBs, the requisite residence time is a function of the concentration of the dissolved contaminants flowing through the PRBs. If the peak concentrations of the contaminant in the aquifer are not defined (e.g., because of sample blending in conventional wells), the PRB may be under-designed, leading to insufficient residence time and contaminant breakthrough.

It should also be noted that there are likely many instances where PRBs (or wells used for pump-and-treat remediation) have been installed deeper than they need to be. When conventional single-interval monitoring wells are used to define the maximum depth of contamination at a site, it is usually assumed that the contamination extends to the portion of the aquifer corresponding to the bottom of the well screens. Depth-discrete multilevel monitoring may show, however, that the contamination is limited to much shallower depths. Thus, the PRB may not need to extend to as great a depth as otherwise thought. Because the installation costs of PRBs rise considerably with depth, significant cost savings can be had by accurately defining the vertical extent of contamination using multilevel monitoring wells or depth-discrete DP ground-water samplers.

Site assessment technologies and practices have been changing rapidly in the last decade. As the biases associated with long-screened monitoring wells have become recognized, many practitioners have been installing monitoring wells with shorter well screens. It is not uncommon now to see monitoring wells being installed with screen intervals as short as 2 or 3 ft. While this is a favorable development as it reduces the sampling biases associated with long screens, it also increases the likelihood that high-concentration zones may be missed if only one monitoring well is installed at a particular location. In fact, depending on the depth of the monitoring wells, the contamination can sometimes be missed altogether (e.g., if the well screens are positioned too high and yield samples of clean water above a diving plume). Consequently, one short-screened monitoring well per location is not sufficient to define the vertical extent of dissolved contamination. Depth-discrete sampling devices should be installed at several depths at each location to accurately map the vertical extent of dissolved contamination. Sampling devices should also be installed to depths where they extend beneath dissolved plumes, that is, where

the deepest samples no longer detect contamination, or detect it at concentrations that are below a particular threshold value.

---

### **Measurement of Vertical Hydraulic Heads**

The foregoing discussion focused on the importance of accurately mapping contaminant concentrations in three dimensions. Depth-discrete measurement of hydraulic pressures (heads) is also a necessary part of environmental site assessments. Mapping the hydraulic head distribution in three dimensions allows site investigators to make accurate predictions about the movement and future location of dissolved contaminants. Vertical hydraulic gradients are present at most sites, and the magnitudes of vertical gradients often exceed horizontal hydraulic gradients. Upward hydraulic gradients occur in ground-water discharge areas; conversely, downward hydraulic gradients exist where ground-water recharge occurs, and can be exacerbated by pumping of nearby remediation and water-supply wells. Defining the vertical hydraulic head distribution at a contaminated site is an essential part of developing the site conceptual model, and is most often depicted using flow nets or three-dimensional ground-water flow models.

Hydraulic heads are determined by measuring the depth-to-water in a piezometer or short-screened well and subtracting the distance from a known datum (in North America, typically the top-of-casing elevation referenced to feet above mean sea level). Hydraulic pressures can also be monitored continuously using electronic pressure transducers. Pressure transducers as small as 0.39 in. in outside diameter now exist (e.g., Druck Model PDCR 35/D) for use in small-diameter wells and piezometers. If the focus of a particular study is solely on measuring hydraulic heads and not collecting ground-water samples, the pressure transducers can be buried directly to provide single- or multiple-depth hydraulic head data.

Definition of vertical hydraulic gradients is also necessary to judge whether or not ambient vertical flow of ground water is likely occurring in conventional single-interval monitoring wells at a particular site. As discussed in the Sidebar, ambient vertical flow of ground water may occur in monitoring wells and other long-screened wells (e.g., remediation wells or water-supply wells) whenever (1) vertical hydraulic gradients exist in the aquifer and (2) the wells are not being pumped. Ambient vertical ground-water flow in wells can redistribute dissolved solutes in the subsurface, which can result in cross-contamination of the aquifer and chemically biased samples being collected from the wells. If no vertical hydraulic gradients exist in the portion of the aquifer screened in a particular well, however, ground-water flow can be assumed to be horizontal through the well and vertical flow and redistribution of contaminants may not be a problem. If there is reason to believe that ground water flows horizontally through the well, the well can sometimes be sampled in a way that sheds light on the natural vertical distribution of dissolved contaminants in the portion of the aquifer screened by the monitoring well. A discussion of techniques that can be used to collect depth-discrete samples from single-interval monitoring wells is presented later in this chapter.

---

### **One Time Sampling versus Permanent Multilevel Monitoring Devices**

There has been a growing trend in the last decade to collect one-time ground-water samples at sites underlain by unconsolidated sedimentary deposits using single-interval



direct-push (DP) samplers such as the Hydropunch<sup>TM</sup>, BAT sampler, and other DP ground-water sampling tools generically referred to as “sealed-screen samplers” (U.S. EPA, 1997). These tools allow site investigators to collect ground-water samples from discrete depths without having to install permanent monitoring wells. Most of the tools are, however, designed to collect samples from single depths. If samples are desired from multiple zones, the tools usually must be retrieved, emptied of their contents, cleaned, and re-advanced to the next sampling depth. Thus, obtaining a vertical profile of contaminant concentrations from many depths can be a time-consuming process with most DP ground-water sampling tools. Another tool, the Waterloo Ground-Water Profiler, allows for the collection of discrete ground-water samples from multiple depths without having to retrieve and re-deploy the sampling tool between different depths (Pitkin et al., 1999). A similar tool, the Cone-Sipper<sup>TM</sup> is typically used with cone penetrometer testing rigs. Another comparable tool, the Geoprobe Ground-Water Profiler, is also available. All these DP ground-water sampling tools are described in detail in Chapter 6.

One-time DP ground-water sampling tools have some advantages over permanent multilevel-monitoring wells. First, it is generally faster to collect depth-discrete ground-water samples using DP sampling tools than to install, develop, and sample permanent multilevel ground-water monitoring wells. Secondly, many site owners dislike having permanent or semipermanent monitoring devices installed on their properties. The wells must be protected during site demolition and reconstruction activities, tracked through all property transfers, and then decommissioned when they are no longer needed. Also, many responsible parties (RPs) fear that if they have permanent monitoring wells on their property, the regulatory agency overseeing the work will require them to monitor the wells for an indeterminate and possibly protracted period of time.

DP ground-water sampling tools, however, often do not tell the whole story. For example, they do not provide information about the vertical hydraulic head distribution at a particular site. Also, one of their main advantages — the fact that they are used to collect one-time samples — is a drawback at many sites. Monitoring a plume over time with DP sampling equipment requires remobilization of the DP contractor and re-advancement of the DP sampling tools each time another round of samples is desired. This becomes costly if long-term ground-water monitoring is needed. Also, the samples are collected with driven probes and the resulting probe holes are usually grouted after the last sample has been collected. It is therefore not possible to obtain samples from exactly the same points in the aquifer at a later date. Consequently, exclusive use of DP ground-water sampling tools is generally not cost-effective at sites where ongoing ground-water monitoring is needed.

So, when and where should permanent multilevel ground-water monitoring systems be installed? First, they should be installed whenever and wherever it is necessary to determine the vertical hydraulic head distribution. Because measuring vertical hydraulic heads is fundamental in the development of a site conceptual model, installation of multilevel monitoring wells or piezometers that allow for measurement of hydraulic heads at multiple depths is needed at virtually every contaminated site. Measuring temporal changes in hydraulic heads at a site is particularly important in understanding the ground-water flow system, mixing mechanisms, and contaminant distribution. Secondly, any time that ongoing, long-term multilevel water quality monitoring is needed, permanent multilevel ground-water monitoring devices should be installed. Considering that ongoing ground-water monitoring (of hydraulic heads and chemistry) is needed and required at most contaminated sites, permanent multilevel monitoring devices should play an important role at most sites. For example, long-term ground-water monitoring is often necessary to verify the effectiveness of active remediation. At other sites, time-series samples may need to be collected to document suspected seasonal fluctuations in

the concentration or flux of contaminants emanating from a residual NAPL source zone. And, of course, long-term multilevel monitoring is necessary at sites where monitored natural attenuation is the selected remediation method (see Chapter 9). Permanent multilevel monitoring wells should therefore be utilized at most contaminated sites.

Careful planning should be undertaken to select the optimal locations and depths for the multilevel devices. In unconsolidated sedimentary deposits, it is usually good practice to first define the general location and depth of the dissolved contaminant plume using DP ground-water sampling tools. Then, multilevel monitoring devices can be installed at the locations and depths that provide the maximum information.

This chapter focuses on permanent multilevel monitoring devices, and Chapter 6 presents a discussion of DP methods for collecting one-time samples. Both are important technologies used to characterize contaminated sites in three dimensions.

---

### **Where You Monitor is as Important as How You Monitor**

The locations of ground-water monitoring wells installed at contaminated sites in the United States have historically been selected in order to provide data used to construct plume maps. Conventional plume maps are two-dimensional, plan-view contour maps of contaminant concentrations obtained from laboratory analyses of ground-water samples collected from monitoring wells. Unfortunately, such maps rarely provide an accurate depiction of the true three-dimensional contaminant distribution due to several factors. These include: (1) the complexity of most dissolved plumes of contaminants; (2) the wide spacing of most monitoring well networks relative to the high-strength plume cores that are often thin and narrow; and (3) variations in concentrations in samples from the wells caused by differences in well depths, screened intervals, and pumping rates (see Sidebar for a discussion of biases associated with conventional monitoring wells).

Ground-water researchers have utilized high-resolution ground-water sampling networks to characterize dissolved plumes at both controlled and accidental release sites in unconsolidated aquifers. A particularly useful approach has utilized transects of closely spaced multilevel monitoring wells or DP sampling points oriented perpendicular to the plume axes (Semprini et al., 1995; Borden et al., 1997; Devlin et al., 2001; Einarson and Mackay, 2001; Kao and Wang, 2001; Newell et al., 2003; Guilbeault et al., 2005) (Figure 11.4). The wells or sampling points are often spaced 20 ft (or less) apart horizontally and facilitate the collection of discrete ground-water samples from multiple depths. The optimal vertical spacing of monitoring points in a sampling transect is a function of many factors (e.g., the purpose of the monitoring, the type of contamination, the nature and geometry of the source zone, subsurface geology, distance from the contaminant source, etc.) and is the subject of ongoing research (e.g., see Guilbeault et al., 2005). A minimum of one transect is installed downgradient from the source zone to define the strength and temporal variability of the contaminant source, or to assess the effectiveness of remediation efforts. Multiple sampling transects are used to evaluate the natural attenuation of contaminants (see U.S. EPA, 1998; Chapter 9 of this book). Recent advances in monitoring technologies described in this and other chapters have made these sampling technologies accessible to environmental consultants and cost-effective for use at non-research sites.

Transects of multilevel wells are superior to monitoring networks comprised of spatially distributed conventional monitoring wells for several reasons. First and foremost, the dense grid or “fence” of sampling points makes it far more likely to detect and accurately

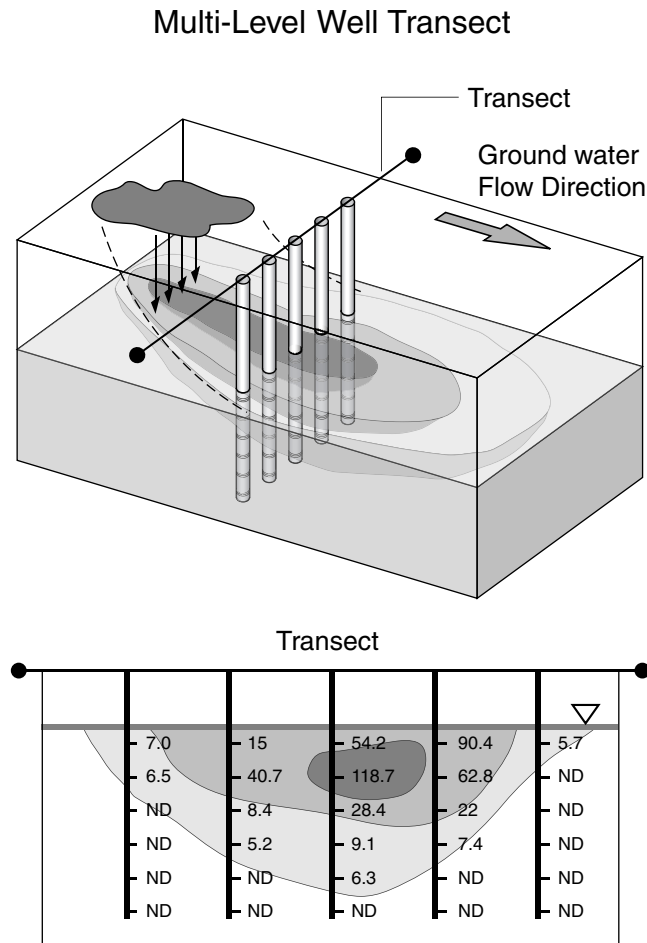

**FIGURE 11.4** Transect of multilevel wells. (Illustration courtesy of LFR Levine–Fricke and the American Petroleum Institute.)

delineate dissolved-phase plumes of contaminants (especially high-strength zones or “plume cores”) than if sparse networks of conventional monitoring wells were used. This is particularly advantageous when the characterization is being performed to determine the optimal width, depth, and thickness of PRBs (Figure 11.5), or the locations and screen intervals of extraction wells used in conjunction with pump-and-treat remediation. Secondly, detailed plume definition may show that plumes that were thought to be co-mingled are actually separate. This is clearly important for fair cost allocation associated with regional cleanup efforts. Thirdly, transects of closely spaced multilevel wells are much less sensitive to slight shifts in the lateral and vertical position of dissolved plumes than sparse networks of conventional wells. For example, in areas where the hydraulic flow systems change over time (e.g., seasonal changes in flow direction), dissolved plumes may shift laterally and vertically in the aquifer. Take, for instance, a well that is screened in a high-strength part of a narrow dissolved plume (or in a single plume core within a larger plume with multiple cores). Samples collected initially from the well would contain high concentrations of the target contaminant. What if the plume core then shifted slightly away from the well (either laterally or vertically) in

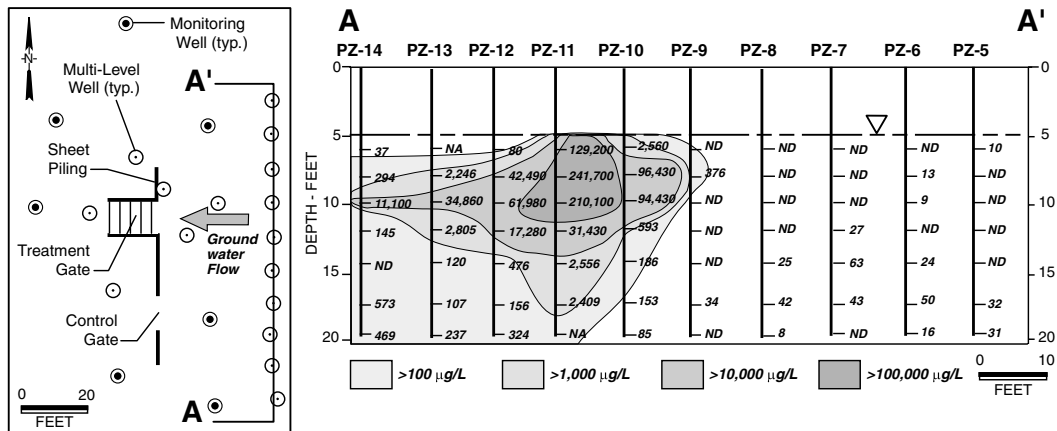

**FIGURE 11.5**

Contours of total chlorinated VOC concentrations along a sampling transect installed upgradient from a funnel-and-gate PRB, Alameda Naval Air Station, CA. (From Einarson and Cherry [2002]. With permission.)

response to a gradual change in lateral or vertical ground-water flow direction? Samples taken over time from the well would contain progressively lower concentrations of the target contaminant simply because the well is sampling lower concentration parts of the same dissolved plume over time. A plot of sampling results for the well would show declining concentrations over time. This trend could logically (but incorrectly) be attributed to source depletion or natural biodegradation. If, on the other hand, the same plume was monitored with a dense network of multilevel wells arranged in a transect across the plume, lateral and vertical shifts in the plume location could be easily recognized. Shifts in the position of the plume are obvious if the data are contoured in a vertical cross-section drawn across the plume (i.e., along the transect) as shown in Figure 11.5. Finally, sampling transects facilitate the calculation of the rate of contaminant migration, referred to as contaminant mass discharge or total mass flux. Feenstra et al. (1996) defined the plume mass discharge as the amount of contaminant mass migrating through cross-sections of the aquifer orthogonal to ground-water flow per unit of time. Contaminant mass discharge is a powerful site characterization parameter that, at some sites, may allow site investigators to predict the potential impact a plume may have if it were to be captured by a downgradient water supply well (Einarson and Mackay, 2001). Monitoring changes in contaminant mass discharge along the flow path has also been advocated as a way to perform more quantitative evaluations of natural attenuation (U.S. EPA, 1998). Characterizing dissolved plumes on the basis of contaminant mass discharge, therefore, allows site owners and regulators to focus cleanup efforts on the sites that pose the most significant threat to downgradient receptors (Feenstra et al., 1996; U.S. EPA, 1998; Einarson and Mackay, 2001; Newell et al., 2003).

The above discussion notwithstanding, there are times when individual multilevel wells or individual clusters of monitoring wells distributed more broadly over a site are appropriate. For example, individual multilevel wells or well clusters may be areally distributed at a site to provide information regarding the three-dimensional distribution of hydraulic head. Definition of the hydraulic head in three dimensions is needed to understand the ground-water flow system, calibrate numerical models, and estimate the probable location and trajectory of a dissolved plume prior to installing detailed sampling transects.

---

## Options for Multilevel Ground-Water Monitoring

More options and technologies exist now than ever before for measuring hydraulic heads and collecting discrete ground-water samples from multiple depths at contaminated sites. Technologies for multilevel ground-water monitoring include nests of wells installed in single boreholes and clusters of wells completed to different depths. Several specialized multilevel monitoring systems are also commercially available. These technologies are described in the following sections. Also, it may be possible in some cases to obtain information regarding the vertical distribution of dissolved contamination by carefully collecting depth-discrete samples from within conventional single-interval monitoring wells. The next section begins with a discussion of techniques for performing depth-discrete sampling in conventional single-interval monitoring wells and explains when those techniques can and cannot be relied upon to yield data that accurately depict the concentrations and distribution of contaminants in the portion of the aquifer screened by the wells.

### Multilevel Sampling within Single-Interval Monitoring Wells

In recent years there has been a growing trend toward measuring vertical contaminant "profiles" within conventional single-interval wells. In some cases, it may be possible to collect multidepth ground-water samples from single-interval monitoring wells that shed light on the vertical distribution of contaminants in an aquifer. However, as discussed, this is not necessarily a simple task and conventional sampling equipment and approaches often do not yield satisfactory results. New technologies such as passive diffusion samplers may yield better results but they can easily be misapplied, resulting in data that can be misinterpreted.

#### *Multiple Diffusion Samplers Installed inside Single-Interval Monitoring Wells*

A thorough discussion of passive diffusion samplers is presented in Chapter 15. The information in this section therefore augments the material presented in Chapter 15, specifically as it relates to the placement of multiple diffusion samplers in a single monitoring well in an attempt to gain information regarding the vertical distribution of contaminants in the subsurface. The first step in this effort consists of installing diffusion samplers at multiple depths in the screened interval of a monitoring well. The diffusion samplers are made of either dialysis cells or polyethylene bags (further discussion of each of these types of samplers is presented). The sample bags or dialysis cells contain deionized, organic-free water, which is physically isolated from ground water in the monitoring well by a thin sheet or membrane of polyethylene, or, in the case of the dialysis chamber sampler, a cellulose membrane. In theory, dissolved contaminants flowing through the well under natural flow conditions diffuse through the membrane and into the water inside the polyethylene bags or dialysis cells. The rate of diffusion is controlled by Fick's law, which incorporates both the diffusion coefficient of the contaminant through the membrane material and the concentration gradient. The samplers are left in the well for a period of up to several weeks and then removed. Samples of the water within the sample bags or dialysis cells are collected and analyzed for the contaminants of interest.

As discussed in Chapter 15, several factors affect the performance of diffusion samplers. These include:

- *The target analyte.* For example, hydrophobic organic compounds like halogenated ethenes and ethanes and aromatic hydrocarbons rapidly diffuse through polyethylene. However, hydrophilic compounds like MTBE and most charged inorganic solutes do not.
- *The exposure period.* The samplers must remain in the well until the concentrations of the target compounds in the polyethylene bags or dialysis cells have equilibrated with the concentrations in the ground water. Because molecular diffusion is a function of compound-specific diffusion coefficients and concentration gradients, the exposure period required to reach equilibration varies for different target compounds and different sites (because dissolved concentrations in ground water differ between sites and even between the depths of the different sample bags or containers in the same well).
- *Well construction.* It is assumed that ground water flows unobstructed through the well under ambient flow conditions. This may not be the case for wells that are not in good hydraulic connection with the borehole. Poor hydraulic connection may occur due to smearing of clays on the borehole wall during drilling, compaction of displaced soil (in the case of DP well installation), or inadequate well development.

There is an additional factor that must be considered when multiple diffusion samplers are placed inside single-interval monitoring wells in an effort to define the vertical distribution and extent of contamination in an aquifer. The factor is the assumption that ground water is flowing horizontally through the well. If there are vertical hydraulic gradients in the aquifer (even small ones), there may be ambient vertical flow of ground water in the monitoring well (see Sidebar). In that case, the multidepth diffusion samplers will come in contact with ground water flowing both horizontally and vertically within the well and not ground water flowing solely horizontally in the aquifer at the depth where the samplers are placed. Samples collected from the passive samplers may therefore accurately reflect the concentrations of the solute of interest *in the well* at the depths of the samplers, but they would not reflect the actual distribution of contaminants *in the aquifer* at these depths. The resulting data may therefore be ambiguous and misleading. To avoid this, the use of multiple diffusive samplers placed in a single well screen to obtain depth-discrete samples should be done only in aquifers where ground water is known to be flowing horizontally. Before diffusion sampling devices are installed in the well, site data should be reviewed to ensure that there are no vertical gradients in the formation. As discussed earlier, this can be done by examining vertical head data from multilevel wells or well clusters. Alternatively, borehole flowmeter surveys can sometimes be performed in the well prior to installing the samplers to directly measure whether or not ambient vertical flow of ground water is occurring in the well.

#### *Diffusion Multilevel System*

The diffusion multilevel system (DMLS) was the first diffusion sampler designed to collect multidepth samples from single-interval monitoring wells. Developed by researchers at the Weizmann Institute of Science in Israel in the 1980s, the DMLS utilizes multiple 20 ml dialysis chambers positioned at different depths in the well to collect samples containing dissolved solutes that flow through the monitoring well under ambient conditions (Ronen et al., 1987). Deionized water is placed in the chambers prior to insertion of the

DMLS into the well. Solutes in the ground water flowing through the well diffuse into the dialysis chambers. After a few weeks, the DMLS is removed from the well and samples from the various chambers are collected and analyzed. The DMLS can be used to collect samples containing a variety of inorganic and organic compounds, including chloride, nitrate, sulfate, dissolved oxygen, tetrachloroethylene, and 1,1,1-trichloroethane. Rubber or Viton washers are placed between the various dialysis chambers to reduce or eliminate vertical flow of ground water within the well. More detailed descriptions of the development and testing of the DMLS are presented in Ronen et al. (1987). An evaluation of multidepth ground-water sampling that included the DMLS is presented in Puls and Paul (1997).

The system became commercially available in the U.S. when the patent rights were acquired by Johnson Well Products, Inc. Johnson sold the DMLS worldwide between 1994 and 1998, but discontinued its sale of the DMLS in 1998 when Johnson was acquired by the Weatherford Company. Ownership of the DMLS reverted to the Margan Corporation, an Israeli company with offices in the U.S. Information regarding the availability of the DMLS can be obtained by contacting the Margan Corporation ([www.margancorporation.com](http://www.margancorporation.com)).

#### *Passive Diffusion Bag Samplers*

As discussed in Chapter 15, diffusion bags made of polyethylene have recently become available for passive sampling of dissolved volatile organic compounds (VOCs). An early application of the bags was to delineate the location of a VOC plume discharging to surface water (Vroblecky et al., 1996). Passive diffusion bag (PDB) samplers have subsequently been used to collect ground-water samples from monitoring wells (Vroblecky and Hyde, 1997). One of the claimed advantages of using PDB samplers for collecting ground-water samples from monitoring wells is that there is essentially no disruption of the flow in the well during sample collection, because no pumping occurs. There is, of course, disruption and mixing of water in the well when the PDB samplers are being inserted into the well. But, the mixed water in the well is usually flushed away by natural flow through the well during the week or two that the PDB samplers are left to equilibrate in the monitoring well.

Several PDB samplers can be tied together and suspended in a monitoring well to obtain information regarding the stratification of contaminants in the well (Vroblecky and Hyde, 1997). While this is appealing in concept, the data must be interpreted with the awareness that ambient vertical flow in the well may have created a vertical distribution of the target VOCs in the well that differs significantly from that which exists in the aquifer (see Sidebar). Consequently, the results may be misleading and can result in either underestimating or overestimating the risks to potential receptors and improper remediation system design.

#### ***Active Collection of Samples from Multiple Depths within a Single-Interval Well Using Grab Samplers or Depth-Discrete Pumping***

The earlier discussion describes passive methods of collecting depth-discrete samples from monitoring wells using PDB samplers. There are also "active" methods for collecting ground-water samples from various depths in a single-interval monitoring well. These include grab or "thief" samplers (e.g., pressurized bailers, the Kabis Water Sampler<sup>TM</sup>, the Hydrasleeve<sup>TM</sup>) and pumping methods. Like PDB samplers, however, these active sampling methods simply yield samples from multiple depths in the well, which may or may not represent the distribution of the target solutes in the aquifer due to possible ambient vertical flow of ground water in the well as discussed earlier.

*Grab or Thief Samplers*

Grab or "thief" samplers (e.g., the Discrete Interval Sampler<sup>TM</sup>, Kabis Water Sampler, Hydrasleeve, Pneumo-Bailer<sup>TM</sup>, etc.) are nonpumping devices used to collect depth-discrete samples of ground water from a well. The devices are lowered into a well to a target depth and then actuated to collect a ground-water sample from specific depth. In the case of the Discrete Interval Sampler<sup>TM</sup>, the sampler is pressurized at the ground surface, which seats a check valve in the sampler, thereby preventing water from entering it. When the sampler is at the target depth, the pressure is released. This opens the check valve and allows ground water from the target depth to flow into the sampler. The sampler is then re-pressurized, thereby preventing the introduction of ground water from other intervals into the sampler while it is being retrieved. The procedure is repeated to collect samples from other depths in the well. For more information about the samplers, the reader is referred to an evaluation of five discrete interval ground-water sampling devices performed by the U.S. Army Corps of Engineers (Parker and Clark, 2002) and to Chapter 15 of this book. Grab or thief samplers are also used to collect depth-discrete samples from wells (both monitoring wells and water-supply wells) that are being pumped as the samples are being collected. Collecting depth-discrete samples from wells as they are being pumped has been shown to be a useful technique to determine where contaminants are entering the wells (Foote et al., 1998; Jansen, 1998; Gossell et al., 1999; Sukop, 2000).

Using grab or thief samplers to collect depth-discrete samples under non-pumping conditions may sometimes yield ambiguous results. First, ambient vertical flow in the well may have redistributed contaminants in the well prior to sample collection (see Sidebar and earlier discussion). Secondly, the process of lowering the sampler to the target depth(s) may cause considerable mixing in the well. Thus, the sample collected may be a mixture of water from other zones, even if the contaminant distribution in the well closely matched that in the aquifer prior to lowering the sampler into the well. Also, lowering the sampler into the well and removing it may create a plunging action that can significantly increase the turbidity of water in the well. This can cause a significant sampling bias, especially when the target analytes include dissolved metals (Parker and Clark, 2002). If time allows, it is desirable to let sufficient time pass after lowering the sampler to the desired depth, but before collecting the sample, to restore the natural flow condition in the well. From single-well tracer-test theory, the time needed for the mixed water to be purged from the well by natural ground-water flow (assuming flow is horizontal through the well) is approximately 0.5 times the effective diameter of the well, divided by the Darcy velocity (Drost et al., 1968; Freeze and Cherry, 1979).

*Collecting Depth-Discrete Samples by Pumping from Different Depths in Well Screens*

There have been many instances where site investigators have attempted to gain insight into the vertical distribution of dissolved contaminants in an aquifer by sequentially pumping at low flow rates from different depths in a long well screen. Typically, "profiles" of solute concentrations have been obtained by collecting a series of samples obtained with the sampling pump placed at different depths in the well screen interval. The sampling pumps used for this purpose have included submersible pumps, bladder pumps, or simply small-diameter "drop tubes" attached to a peristaltic pump at the ground surface. Whether or not the samples collected in this manner yield insight into the vertical distribution of solutes in the adjacent aquifer is neither certain nor straightforward to evaluate. The data would, of course, be strongly biased if ambient vertical flow within the well has redistributed contaminants in the well as discussed earlier. However, even for wells where vertical gradients are absent and ground water flows horizontally through the well, pumping at low rates from different depths in the well screens may yield equivocal data depending on when



the samples are collected after pumping begins. Studies by Martin-Hayden (2000a, 2000b) show that the water extracted immediately after pumping begins is derived from the region nearest the pump intake. As pumping proceeds, water pumped from the well becomes a mixture of water stored in the well and ground water entering the well screen from the formation. Therefore, the very first volume of water pumped from the well is most representative of the water quality adjacent to the pump intake. This initial volume of water is what should be sampled and analyzed if the goal is to obtain a sample that is most representative of water quality in the aquifer at the depth of the pump intake. As pumping proceeds, the extracted water becomes less and less representative of ground water near the pump because it contains water that has been transported from portions of the well screen further and further away from the pump intake. Given sufficient time and continued pumping, the well will be fully purged and the sample collected will be a flow-weighted composite of the ground water flowing into the entire well screen. Recent simulations of steady-state low-rate flow into a long-screened monitoring well support the hypothesis that under steady-state pumping conditions (i.e., when the well has been fully purged), the depth of the pump intake has no effect on the quality of water extracted during pumping (Varljen et al., 2004).

### Nested Wells (Multiple Tubes or Casings in a Single Borehole)

Nested wells are multilevel monitoring wells in which multiple tubes or casings are installed at different depths within the same borehole (Figure 11.6). In order to measure depth-discrete hydraulic heads and collect depth-discrete ground-water samples, each well screen in the nested well should be no more than 2 or 3 ft in length. Types of nested wells include bundles of small-diameter tubing or PVC casing where physical separation between the intakes of the sampling tubes or pipes is provided by sand that collapses around the tubing or pipes as soon as the insertion pipe is withdrawn. In noncollapsing formations, annular seals must be installed inside the borehole to prevent hydraulic

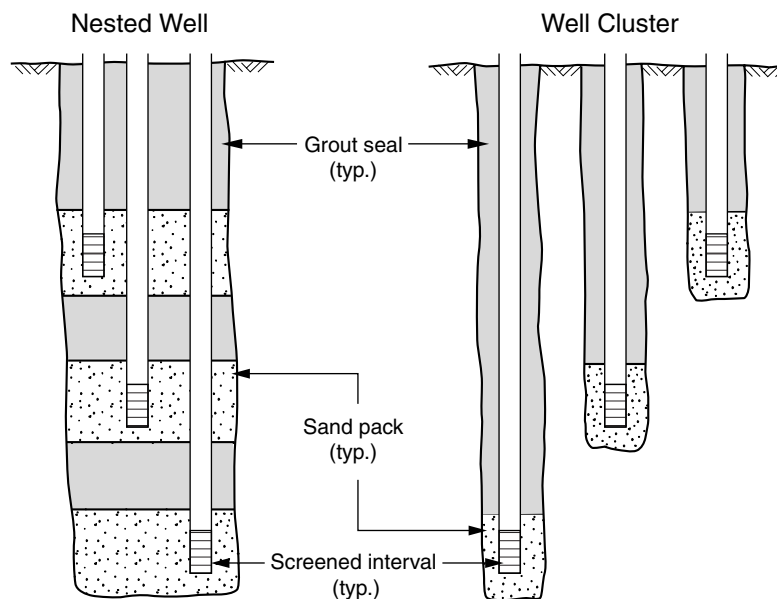

**FIGURE 11.6**  
Nested well and well cluster. (Adapted from Johnson [1983]. With permission.)

connection between the various monitored zones. Installation of the annular seals in nested wells must be done carefully to prevent hydraulic connection between the different monitoring zones. Nested wells with annular seals between monitored zones were the most popular types of multilevel monitoring wells in the 1970s and early 1980s. However, several well-publicized failures of nested wells caused many state and Federal regulatory agencies to ban or discourage their construction. Nested wells are still being installed and, in fact, are experiencing a renaissance due to the growing awareness of the importance of multilevel ground-water monitoring. Important issues related to annular seals in nested wells, including methods for improving the quality of the seals, are discussed.

### ***Bundle Wells Installed in Collapsing Sand Formations***

Ground-water researchers studying unconsolidated sedimentary aquifers have used bundles of small-diameter flexible tubing for over 30 yr to collect depth-discrete ground-water samples from as many as 20 different depths in the same borehole (Cherry et al., 1983; Reinhard et al., 1984; Mackay et al., 1986). A typical bundle well design is provided by Cherry et al. (1983) and is depicted in Figure 11.7. Each tube in the bundle has a maximum intake length (i.e., screen length) of approximately 10 cm. A variation of this design, using multiple 0.5-in. PVC pipes, has been used successfully to collect depth-discrete ground-water samples during recent comprehensive studies of a dissolved MTBE plume in Long Island, NY (Haas and Sosik, 1998) (see Figure 11.8).

The bundles of tubing or pipe are typically installed inside a driven insertion tube or pipe that has been advanced to the maximum depth of the well. When the insertion tube is withdrawn, sand collapses around the tubing bundle. Whether or not every void space between every tube or pipe is filled with sand is not certain, but experience gained from many hundreds of such installations in collapsing sand formations at detailed field research sites shows that vertical flow of contaminants along the well bundles is not significant. Nonetheless, bundle wells should only be used when and where the site investigator is confident that the formation will fully collapse around the tubing bundle and where strong vertical hydraulic gradients are absent. Bundle wells are easily installed using DP sampling equipment.

Water samples are usually collected from these types of wells using peristaltic pumps or small-diameter tubing check-valve pumps (e.g., Waterra™ pumps). If the tubing or pipe is large enough, small-diameter water-level meters can be used to measure the depth to water inside the tubes or pipes. If the tubes are too small to measure water levels using electronic water-level meters and the static depth to water is less than 25 ft or so, a sufficient vacuum can be applied simultaneously to all of the tubes to raise the water levels to an elevation above the ground surface. Relative hydraulic heads in the various tubes can be measured using sight tubes. Absolute head values for each zone can be obtained by subtracting the applied vacuum (converted to units of feet or meters of water) from the elevation of the water levels in the sight tubes.

### ***Nested Wells Installed with Seals between Monitored Zones***

A conceptual design of a nested well is shown in Figure 11.6. In the diagram, there are bentonite or grout seals between the various screen and sand pack intervals. These seals are installed by pouring bentonite chips (or pumping cement or bentonite grout) into the borehole as the well is being built. Building the well therefore starts with pouring sand into the borehole until the sand rises to a depth above the deepest well screen. Then, the bentonite or grout seal is placed in the borehole annulus up to a depth just below the next deepest well screen. Next, sand is poured into the borehole to cover the screen for that zone. The process of adding alternating layers of sand and bentonite (or

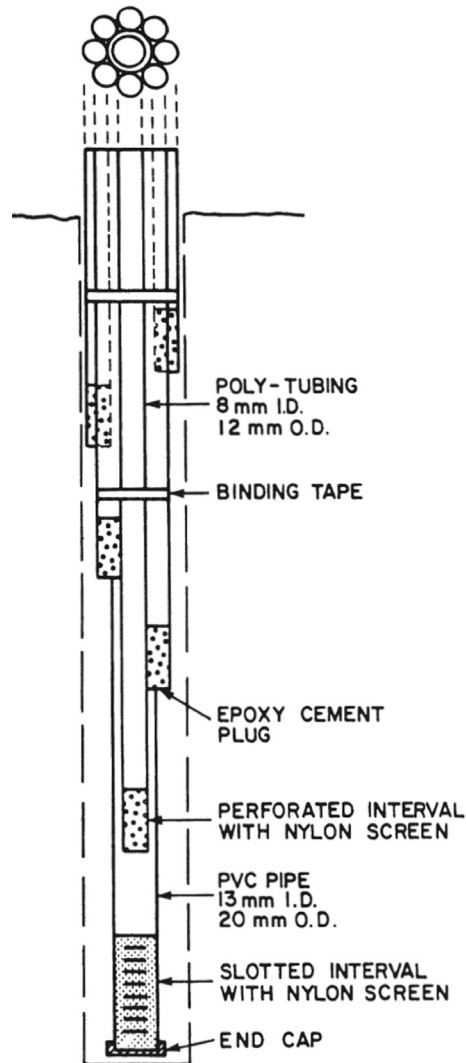

**FIGURE 11.7**  
Bundle well. (From Cherry et al. [1983]. With permission.)

cement grout) continues until the well is fully built. Building a well like this is time consuming, and particular attention must be paid to avoid adding too much sand or bentonite. If too much sand is added, the thickness of the overlying bentonite seal may be inadequate and the seal jeopardized. If too much bentonite (or cement) is added, the screens of the next monitoring zone may be covered and rendered useless. Consequently, when building a nested well, the depth of the sand or bentonite should be measured frequently as the annular materials are being placed to avoid adding too much sand or seal material. One of the most important tools a driller has when building nested wells is a weighted measuring line or "tag line" which allows him to accurately measure the depth of the annular fill materials as the well is being built. Weighted measuring lines used for well construction are often home made or can be purchased commercially.

Even if the annular seals are placed to the exact depths specified in the well design, there are other reasons why the seals between the monitored zones may be compromised. Few

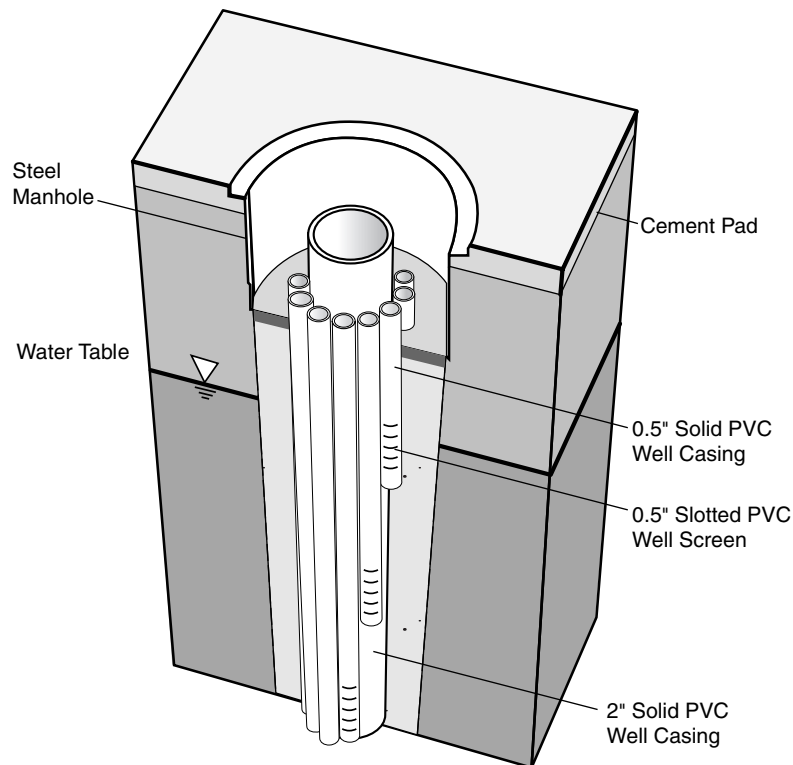
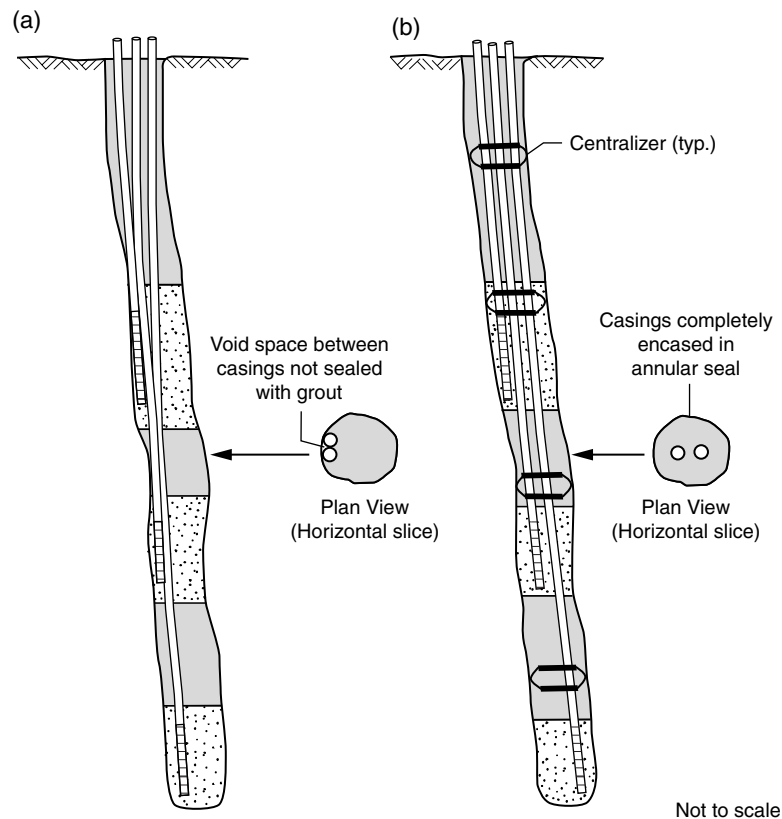

**FIGURE 11.8**

Bundle well made of 0.5-in. PVC pipes surrounding 2-in. PVC well casing. (From New York State Department of Environmental Conservation.)

nested wells are actually constructed like the one depicted in Figure 11.6. A more realistic construction diagram is shown in Figure 11.9a. No borehole is perfectly plumb and straight. Consequently, unless specialized centralizers are used, it is difficult to keep multiple casings centered and separate from one another in the borehole during well construction. If the casings are not centered and separate in the borehole, void spaces can exist in the seal between the various casings and borehole wall. The void spaces can then allow vertical movement of ground water within the borehole between zones. Flow (and therefore cross-contamination) can occur between zones during purging and sampling when strong vertical hydraulic gradients are induced by pumping. Ambient flow and cross-contamination can also occur between zones if vertical hydraulic gradients naturally exist in the formations being monitored.

The likelihood of vertical leakage through the annular seals of a nested well increases with the number of separate casings within the borehole. Also, the likelihood of vertical leakage is higher with shallow nested wells where only a few feet of an annular seal exists between the various monitored zones. It is for these reasons that the installation of nested wells is discouraged or prohibited by many governmental or regulatory agencies. For example, nested wells are prohibited in the State of Washington (State of Washington, 2004). The California Department of Water Resources notes that it can be difficult to install effective seals in nested wells (California Department of Water Resources, 1990). The U.S. Army Corps of Engineers prohibits the use of nested wells (U.S. Army Corps of Engineers, 1998). And, the U.S. EPA notes that "data may be erroneous and the use of nested wells is discouraged" (U.S. EPA, 1992).

**FIGURE 11.9**

Nested wells. (a) Installation without centralizers may result in imperfect seals between monitored zones. (b) Centralizers keep casings separate and centered in the borehole, resulting in superior seals between the monitored zones.

Further, Johnson (1983) notes that:

The existence of several pipes or tubes in a single borehole and the utilization of shorter seals to accommodate the spacings between the monitoring points makes single-borehole completions more difficult to seal than the individual wells

Aller et al. (1989) state in the *Handbook of Suggested Practices for the Design and Installation of Ground Water Monitoring Wells* that:

A substantial problem with this type of construction is leakage along the risers as well as along the borehole wall. The primary difficulty with multiple completions in a single borehole is that it is difficult to be certain that the seal placed between the screened zones does not provide a conduit that results in interconnection between previously non-connected zones within the borehole. Of particular concern is leakage along the borehole wall and along risers where overlying seals are penetrated. It is often difficult to get an effective seal between the seal and the material of the risers.

The above cautions and caveats notwithstanding, not everyone installing nested monitoring wells has experienced failed seals between the monitoring zones. The U.S. Geological

Survey (USGS) has reportedly had success installing nested wells even without the use of spacers or centralizers to keep the casings separate in the borehole (Hanson et al., 2002). The USGS installations typically use bentonite slurry to seal between zones. Other reasons why the USGS nested wells have been more successful than others may be that their wells are often very deep (several hundreds to thousands of feet deep), resulting in seals that are several tens to hundreds of feet thick. Also, the USGS drills relatively large boreholes (12 in. or larger) and rarely installs more than three casings in a single hole. A diagram of a nested well constructed by USGS is shown in Hanson et al. (2002).

There are often suggestions that spacers or centralizers be used to keep the various casings separate and centered in the borehole. Some regulations even require it (e.g., California Department of Water Resources, Santa Clara Valley Water District). As shown in Figure 11.9b, centralizers keep the casings separate and centered and can greatly enhance the integrity of the annular seals between the monitored zones. So, why are not spacers or centralizers more widely used during the installation of nested wells? The answer may be that there are no commercially available spacers or centralizers designed for installing nested wells. Conventional well centralizers are designed to center a single casing in a borehole. One type of centralizer for nested wells was used to install nested monitoring wells to depths over 200 ft in California, but those centralizers had to be welded to the various casings, necessitating the use of steel casing for the wells instead of PVC (Nakamoto et al., 1986).

Many drillers have found that using custom-made centralizers to center multiple casings in a single borehole often makes it more difficult, rather than easier, to install reliable annular seals. This is because the centralizers form obstructions to sand and bentonite that is being poured from the surface, causing bridging. Also, there is often no room to insert a tremie pipe into the borehole when such centralizers are used. And, measuring or "tag" lines can become tangled on the centralizers during well construction.

Figure 11.10 shows the design of a well centralizer designed for nested wells.<sup>1</sup> The centralizer assembly uses two 1.5-in.-thick PVC spacer discs that are attached to a conventional 6-in. "lantern" style steel or PVC centralizer. The centralizer assembly is designed for installing three 1-in. PVC wells within a borehole 8 in. or larger in diameter. A novel feature of this centralizer is that it has a hole in the center of each spacer disc to facilitate the use of a 2-in. tremie pipe during well construction. A three-zone centered nested well is constructed as follows. First, a 2-in. tremie pipe is inserted to the bottom of the borehole. Next, two of the PVC spacer discs are threaded over the 2-in. tremie pipe. The first (deepest) 1-in. well screen is attached to the discs by pushing it into the 1-in. cutouts in the discs. The lantern centralizer is then attached to the two discs, securing the 1-in. PVC to the disc or centralizer assembly, and the centralizer and 1-in. PVC are lowered into the borehole. At the depth corresponding to the next centralizer, the process is repeated. At the depth corresponding to the middle monitoring zone, the second well screen is attached to one of the other cutouts in the centering discs. Centering discs and centralizers are assembled and sections of 1-in. PVC casing are attached in this way until the entire three-zone nested well has been fully inserted to the bottom of the borehole. The sand and bentonite seals are then installed by pouring the materials through the 2-in. tremie pipe as it is removed from the borehole. The 2-in. tremie is sufficiently large to pour sand and bentonite pellets through it. A measuring line can also be run inside of the 2-in. tremie to measure the depths of the sand and bentonite lifts as the well is being constructed. The tremie pipe is incrementally removed from the borehole as the well is constructed.

<sup>1</sup>The centralizer assembly described here is not commercially available but can be easily fabricated by most drilling contractors.

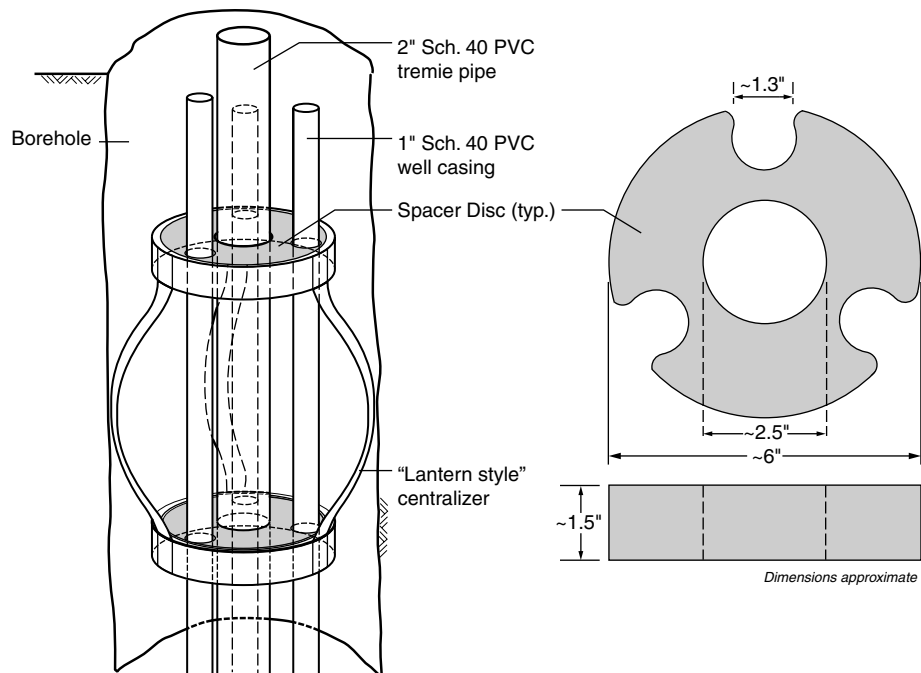
**FIGURE 11.10**

Design of a centralizer for a three-zone nested well. See text for further discussion.

### Well Clusters (One Well per Borehole)

A cluster of monitoring wells is a grouping of individual wells, each completed to a different depth (Figure 11.6). The main advantage of well clusters over nested wells is that the seals are easier to install and more reliable because there is only one casing in each borehole. It is for this reason that well clusters are widely recommended by governmental and regulatory agencies. As with nested wells, the screened interval of each well in the cluster should be no more than 2 or 3 ft long so that the head measurements and ground-water samples from each well will be depth discrete and not composited over a larger part of the aquifer.

The main disadvantage of clusters of wells is the increased cost of drilling separate boreholes for each well. Costs for well clusters are especially high if each borehole needs to be continuously cored. In some cases it is sufficient to continuously core the deepest boring and then design the entire well cluster based on the data obtained from the single core. However, if one expects significant variations in the geology, even over short horizontal distances (e.g., in fractured bedrock or fluvial deposits), then each borehole in the cluster should be cored. This can add significant cost to the well cluster installation.

In plan view, the individual wells in the cluster should be installed close together, on the order of 10 ft apart or less, so that the head data obtained from them is a result of variations in the vertical head and not horizontal gradients. Also, care should be taken to avoid installing clusters of monitoring wells with overlapping screens. As shown in Figure 11.11, overlapping screens can allow vertical movement of contaminant plumes if vertical hydraulic gradients are present. Finally, clusters of wells should be installed with the wells oriented in a line perpendicular to the flow direction or with the deeper wells located progressively in the downgradient direction. This avoids the possibility

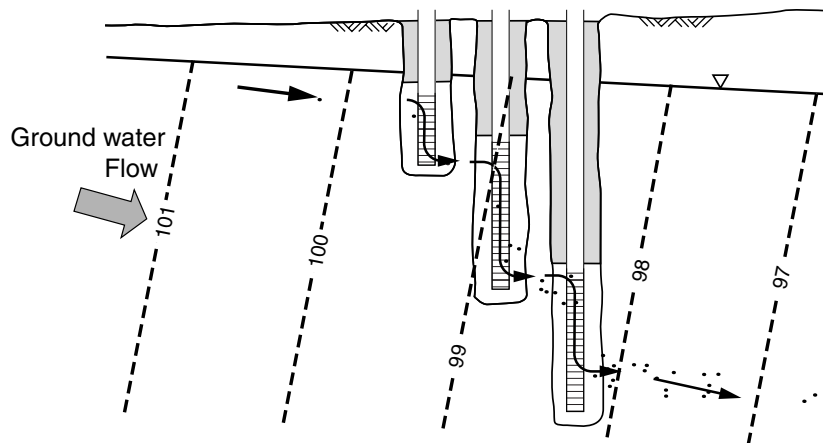

**FIGURE 11.11**

Cluster of monitoring wells with overlapping well screens. If vertical gradients are present, well clusters installed like this can lead to short-circuiting of the contaminant plume and cross-contamination of the aquifer.

that the wells will be sampling ground water that is affected by contact with the annular seal of an upgradient monitoring well.

At sites underlain by unconsolidated sedimentary deposits, the use of clusters of individual wells for multilevel monitoring is becoming more and more economical (and therefore more popular) due to the use of DP installation methods and small-diameter monitoring wells with prepacked well screens. At many sites, several clusters of small-diameter wells can be installed in a single day using powerful DP rigs.

### Dedicated Multilevel Ground-Water Monitoring Systems

There are several dedicated multilevel ground-water monitoring systems currently on the market. Four commercially available systems that have seen relatively widespread use are: the Westbay MP<sup>®</sup> system; the Solinst Waterloo<sup>™</sup> system; the Solinst CMT<sup>™</sup> system; and the Water FLUTE<sup>™</sup> system. A comparison of these systems is presented in Table 11.1; each system is also described in detail below. These dedicated multilevel systems offer the following advantages.

- They facilitate the collection of ground-water samples and measurement of hydraulic heads from many more discrete depths than is practical with nested wells or well clusters (e.g., 10 or more discrete depths can be monitored with most dedicated multilevel monitoring systems).
- Only one pipe (or tube) is placed in the borehole. This simplifies the process of installing annular seals between the monitored zones and improves the reliability of the seals (e.g., compared with nested wells).
- Total project costs can be significantly lower due to reduced drilling costs, less secondary waste, less time spent monitoring and sampling, and fewer wells for decommissioning.
- The volume of purge water produced during routine sampling is decreased or eliminated, reducing costs related to storage, testing, transport and disposal of purged fluids.



**TABLE 11.1**  
Comparison of Four Dedicated Multilevel Ground-Water Monitoring Systems

Description	Westbay MP® System	Solinst Waterloo™ System	Solinst CMT™ System	Water FLUTE™ System	Comments
Materials	PVC, polyurethane, Viton, and stainless steel	PVC, stainless steel, Viton, rubber, and Teflon or polyethylene tubing	Polyethylene and stainless steel	Polyurethane-coated nylon, stainless steel or brass, and polyethylene, PVDF, or Teflon tubing	Materials vary depending on sealing and pumping options
Maximum depth (ft)	4000	750	300	1000	Maximum depth for routine installations
Maximum number of sampling points	20 per 100 ft of well	15	7	20+	With exception of Westbay system, depends on diameter of system and size of sampling tubes
Allows use of pressure transducers to monitor hydraulic pressure	×	×	×	×	Westbay MP system uses a specialized tool for sample collection and pressure measurement (see text) Dedicated pressure sensors can also be installed
Maximum sampling points when dedicated pressure transducers are used in each monitored zone	See comments	8	3	20+	With Westbay MP system, dedicated pressure sensors must be removed prior to collecting ground-water samples from the same zones
Sampling methods	See comments	Peristaltic pump, inertial-lift pump, double-valve pump, bladder pump	Peristaltic pump, inertial-lift pump, double-valve pump	Peristaltic pump, inertial-lift pump, double-valve pump, bladder pump	Westbay system uses specialized tool for sample collection and pressure measurement (see text)
Optimal borehole diameter (in.)	3–6	3–6	3–6	3–10	

(Table continued)

TABLE 11.1 Continued

Description	Westbay MP® System	Solinst Waterloo™ System	Solinst CMT™ System	Water FLUTE™ System	Comments
Built-in features for well development and hydraulic testing	×	—	—	—	
Can be installed immediately after well designed; that is, no delay due to shipping	×	×	×	—	
customized well components to site from factory	×	×	—	×	Solinst Waterloo system removable when deflatable packers used. Deflatable packers under development for Solinst CMT system will make it removable. Successful removal of any multi-level system depends on borehole conditions
Removable system	×	×	—	×	
Can be installed in open holes in bedrock and massive clay deposits	×	×	×	×	
Can be installed in unconsolidated deposits	×	×	×	×	
Can be installed in multiscreened wells	×	×	×	×	
Seals and sand pack can be installed by backfilling from surface	×	×	×	—	FLUTE system seals borehole; other annular seals are therefore not needed
Inflatable packers available for sealing borehole in bedrock or multiscreened wells	×	×	—	—	Inflatable packers under development for Solinst CMT system. Water FLUTE system can be thought of as one long packer
Can be installed with DP (e.g., Geoprobe) equipment	—	—	×	×	

- The small volume of water stored in each monitoring zone or tube minimizes the time required for heads in the well to equilibrate with formation pressures. This is particularly advantageous when multilevel monitoring is performed in low-yield formations and aquitards.
- A single multilevel monitoring well has a much smaller “footprint” at the ground surface than a cluster of individual wells. A single multilevel well is therefore less noticeable and obtrusive than a large cluster of wells.

Dedicated multilevel systems also have some disadvantages, including the following:

- Fewer options exist for sampling dedicated multilevel systems than for conventional monitoring wells. This is due to the design of the wells and the relatively small diameter of sampling tubes installed inside the multilevel wells. Several small-diameter pumps have been developed, however, to facilitate collection of ground-water samples from small-diameter wells and tubing (see following text).
- Owing to the specialized nature of some of the components or monitoring tools used in multilevel systems, some training or technical assistance is generally recommended, at least for first-time installers of the systems.
- It may be more difficult to decommission specialized multilevel monitoring systems than conventional single-interval PVC monitoring wells.

### ***Drilling and Installation Considerations***

#### *Installations in Open Boreholes*

Boreholes drilled into bedrock or silt and clay deposits usually stay open after the hole is drilled and the drill string has been removed. Multilevel wells can therefore be constructed directly inside of the open boreholes. Oftentimes, it is not necessary to have a drilling rig on site during the construction of the multilevel well if the multilevel well casing<sup>2</sup> can be lowered into the borehole by hand or using a winch. Because the boreholes stay open, however, the annular space between the well casing and the boreholes must be sealed to prevent vertical flow of ground water between the various monitored zones. With some multilevel systems (e.g., Westbay MP, Solinst Waterloo), inflatable rubber, polyurethane, or Viton packers can be used to seal the annular space between the monitored zones. The annular space can also be sealed by backfilling the annulus with alternating lifts of sand (at the depths of the intake ports) and clay or cement (in the intervals between the various intake ports). Finally, the novel design of the Water FLUTE system also seals the borehole between the sampling ports.

#### *Installations in Unconsolidated Sedimentary Deposits*

Unlike boreholes drilled into competent bedrock, most boreholes drilled in unconsolidated deposits will not stay open when drilling has been completed and the drill rods are removed. Consequently, some method of keeping the borehole open is necessary while the multilevel well casing is inserted and the well constructed. One way to accomplish this is by advancing steel drive casing as the borehole is drilled. The steel drive casing is left in the borehole while the well casing is inserted, and is then pulled back incrementally as the multilevel well is constructed. If the formation will collapse completely around the multilevel well casing, it is usually not necessary to install annular seals between the monitored zones because the collapsing sand restores the original per-

<sup>2</sup>Or “tubing” in the case of the Solinst CMT system; “liner” in the case of the FLUTE system. “Casing” is used generically in this discussion.

meability of the formation. If the formation will not collapse completely around the multi-level well casing, however, gaps can exist in the annular space, allowing vertical flow of ground water between different monitoring zones. In this case, alternating layers of sand and bentonite or cement must be emplaced by backfilling as the steel drive casing is withdrawn from the borehole. Drilling methods that employ driven casing include air-rotary casing advance and rotasonic (Barrow, 1994). Rotasonic drilling (also referred to simply as sonic drilling) is ideal for installing multilevel monitoring wells because (1) steel drive casing is advanced as drilling progresses; (2) continuous cores are routinely collected (logs of the cores can then be used to design the multilevel wells); and (3) the rate of penetration is usually high.

Two of the multilevel monitoring systems, Solinst CMT and Water FLUTE, can be installed with DP drilling equipment. Both the multilevel systems can be inserted into small-diameter (approximately 3 in. OD) steel casing that has been driven to the target depth. Use of a dual-tube DP system facilitates collection of continuous cores while advancing an outer drive casing that can then be retracted as the multilevel well is constructed (Einarson, 1995). Because of the relatively small size of most DP sampling rigs, however, the maximum depth of multilevel wells installed with this drilling method is approximately 50 ft in most sedimentary deposits.

Multilevel monitoring wells can also be installed in boreholes drilled with hollow-stem augers and mud rotary drilling methods, but these drilling methods have some significant drawbacks. Hollow-stem augers keep the borehole open while allowing the multilevel well casing to be inserted through the augers to the bottom of the borehole. Sand packs and annular seals are then emplaced as the augers are incrementally removed from the borehole. The action of the augers during drilling, however, often creates a skin of smeared fine-grained soil which can seal some thin, permeable strata or fractures in clay (D'Astous et al., 1989) and generally reduce the permeability of the formation along the entire length of the borehole. Also, if the augers penetrate soil containing high concentrations of contaminants (either residual NAPL or sorbed mass), the contaminants can be smeared against the borehole wall from the depth that they were penetrated up to the ground surface. This can impart a long-lived positive bias to ground-water samples collected from a multilevel well subsequently installed in the borehole.

Multilevel monitoring wells can be installed in boreholes drilled with mud rotary drilling equipment, but this drilling method too has undesirable effects when it comes to installing multilevel wells. With mud rotary drilling, the borehole is kept open by (1) the hydrostatic pressure of the drilling fluid (drilling mud) and (2) the creation of a tough, pliable filter cake or clay "skin" that develops from exfiltration of the drilling fluid through the borehole wall. Circulation of the drilling fluid, however, can cross-contaminate the borehole if contaminants in the drilling fluid penetrate the formation (by advection or diffusion) or sorb onto the borehole wall. This can cause a lingering chemical bias similar to the one described above for wells installed with hollow-stem auger drilling equipment. Also, it is often more difficult to place sand packs and annular seals in mud-filled boreholes than boreholes containing air or clear water. This is because the high density and viscosity of the drilling fluid makes it difficult to pour sand and bentonite pellets through the drilling fluid (many contractors will therefore thin the drilling mud with water prior to building a well). In most cases, though, the sand and bentonite or cement must be pumped through a tremie pipe. Finally, the drilling fluid and filter cake may be difficult to remove after the multilevel well has been constructed. With the exception of the Westbay MP system, none of the multilevel systems described in this section facilitate robust well development to remove the drilling mud and filter cake. Therefore, the Westbay MP system would be a good choice for a multilevel well installed in a mud-rotary drilled borehole. Other multilevel systems have been

installed successfully in boreholes drilled using biodegradable drilling fluids (e.g., guar-based slurries), however. The use of a biodegradable drilling fluid reduces the need for vigorous well development to remove the drilling mud and filter cake.

Another way to install the dedicated multilevel systems described in this section is inside of multiscreened wells instead of directly in boreholes (Figure 11.12). With this type of installation, the multilevel monitoring system is installed inside a steel or PVC well that has been constructed with short screens at multiple depths. The depths of the well screens correspond to the depths of the ports in the multilevel monitoring system. This adds another step to the well installation process (i.e., first installing a multiscreened well), but has several advantages. First, installing conventional steel or PVC wells is straightforward and routine for most drilling contractors. Hence, it is not necessary that the drilling contractor have expertise in installing multilevel monitoring systems. Once the multiscreened wells have been installed and developed, the drilling contractor's job is done, and the multilevel systems can be installed by field technicians, often at a lower cost. Secondly, the various monitoring zones can be developed using standard well development equipment and procedures before the multilevel monitoring systems

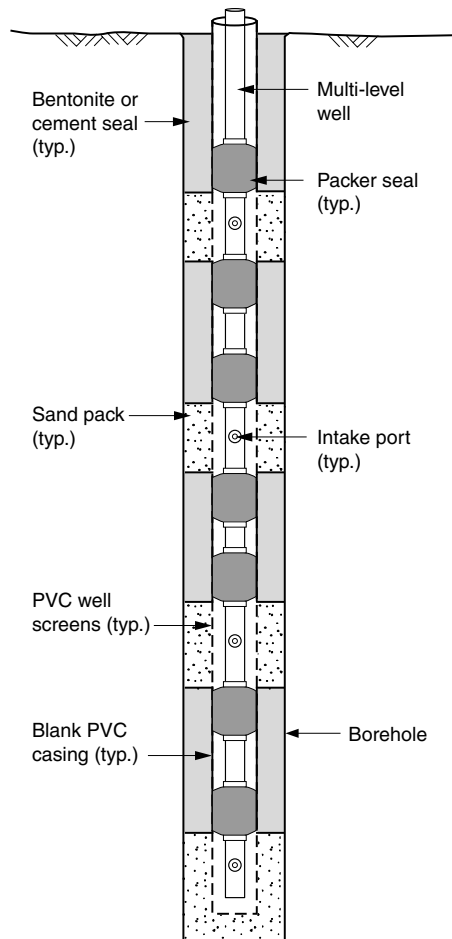

**FIGURE 11.12**

A dedicated multilevel monitoring system installed inside a steel or PVC well constructed with multiple well screens.

are installed in the wells. Finally, installing multilevel systems inside multiscreened wells may simplify the task of decommissioning the wells once they are no longer needed. Most of the multilevel systems can be constructed so that they can be easily removed from the wells. Then, the multi-screened wells can be pressure-grouted or drilled out using standard well decommissioning procedures (see Chapter 12).

#### *Minimizing Cross-Contamination*

A properly constructed multilevel monitoring well should clearly prevent vertical “short circuiting” of ground water between different monitored zones. As discussed earlier, however, cross-contamination can occur in the borehole before the well is constructed. Cross-contamination can occur if NAPL is penetrated and becomes incorporated in the drilling fluid or flows into and along the borehole wall. This severe form of cross-contamination (and ways to avoid it during drilling) is described elsewhere (see Pankow and Cherry, 1996) and is therefore not discussed further in this chapter.

The cross-contamination discussed in this section is related to the redistribution of dissolved solutes within the borehole both during and after drilling — but before the well is constructed. Cross-contamination of fluids in the borehole during drilling has already been discussed and recommendations made to avoid it. In short, when drilling in unconsolidated deposits (both sand and gravel aquifers and low permeability clay deposits), advancing steel casing while drilling is the best way to minimize the potential for cross-contamination of dissolved solutes in the borehole. The drive casing stays in the ground until the multilevel well is ready to be constructed, and is retracted incrementally as the multilevel well is being built. In boreholes drilled in rock, however, it is usually not possible to advance steel casing, and some degree of cross-contamination in the borehole should be expected due to the circulation of fluids (either drilling mud, water, or compressed air). Note that the potential bias caused by circulation of fluids during drilling is not restricted to boreholes drilled for multilevel wells but can occur with all types of monitoring wells.

Further, if a multilevel well is not installed in an open borehole immediately after drilling ceases, vertical flow of potentially contaminated ground water can occur in the borehole from zones of high head to low head during the time that the borehole has been drilled and the multilevel well installed. To minimize potential chemical biases caused by this intra-borehole flow, the multilevel well should be installed in the borehole as quickly as possible. If this is not possible, the borehole can be temporarily sealed to prevent ambient vertical flow. This has been done at several sites using blank FLUTE liners. (Several technologies to temporarily seal boreholes drilled in fractured rock [including FLUTE] are currently being evaluated by researchers at the University of Waterloo [Cherry, 2004].) Partial mitigation of this bias may be accomplished by pumping from the various monitoring zones immediately after the well has been constructed, but low-level contamination may linger for months or years if the contaminants have sorbed onto or diffused into the aquifer matrix (Sterling et al., 2005). The likelihood (and potential longevity) of a positive ground-water sampling bias occurring due to circulation of drilling fluids and intra-borehole ground-water flow after drilling depends on many factors, including the nature and concentration of the contaminant, the nature of the geologic material, the time of exposure, and extent of penetration into the formation, and must be evaluated on a case-by-case basis.

#### *Development of Multilevel Wells*

The purpose of multilevel monitoring wells is to provide depth-discrete samples of ground water and accurate depth-discrete measurements of hydraulic head. They are

not designed to provide large volumes of water as are water supply or remediation wells. Consequently, the requirements for developing multilevel monitoring wells are different than for other types of wells. In general, as long as there is good hydraulic connection between the monitoring ports and the formation and the samples collected from the wells are sediment-free and exhibit turbidity within reasonable levels, the above requirements are met. With each of the dedicated multilevel systems described in this chapter, this level of well development can usually be achieved simply by over-pumping the various ports with the pumps used for sampling. In the case of wells installed in boreholes drilled with mud rotary methods, however, more rigorous development is necessary. This can be accomplished best with any of the four multilevel systems provided that they are installed in multiscreened wells that have already been developed using traditional development methods. Over-pumping is also often done to remove water added to the borehole during drilling and well construction. This is due to widely held concern that if this water is not removed, it could cause a negative bias in the samples subsequently collected from the well. If the volume of water that needs to be removed is small, the water can be removed by pumping the zones using the same pumps used for sampling (the Westbay MP system allows for use of higher capacity pumps for well purging). Air lift techniques have also been used successfully to pump water at relatively high rates from small-diameter sampling tubes (see Einarson and Cherry, 2002). Finally, in most flowing aquifers, it is usually sufficient to simply allow some time to pass before collecting the first samples in order to allow the added water to drift away from the intake ports of the well. In most cases the added water will have drifted away from the intake ports of the multilevel wells in several days and samples collected from the well will be ground water. Some site investigators have added an inert tracer (e.g., potassium bromide) to the water used during drilling and well construction. They then pump water from the various ports (or let sufficient time pass for the added water to drift away from the sampling ports) until the tracer is no longer detected. They can then be confident that ground-water samples collected thereafter consist entirely of ground water and not water added during drilling or well construction.

### **Westbay MP System**

Schlumberger produces the Westbay MP system, a modular instrumentation system for multilevel ground-water monitoring. The MP system can be divided into two parts: (1) the casing system and (2) portable probes and tools that provide a compatible data acquisition system.

The Westbay casing system (Figure 11.13) is designed to allow the monitoring of multiple discrete levels in a single borehole. One single string of water-tight Westbay casing is installed in the borehole. Each level or monitoring zone has valved couplings to provide a selective, controlled connection between the ground water outside the casing and instruments inside the casing. Westbay packers or backfill are used to seal the borehole between monitoring zones to prevent the unnatural vertical flow of ground water and maintain the natural distribution of fluid pressures and chemistry. The Westbay system can be installed in either open boreholes or cased wells with multiple screens.

Westbay system packers are individually inflated with water to pressures of 100–200 psi above ambient. Westbay packers accommodate a range of borehole sizes (Table 11.1) and, according to the manufacturer, withstand significant gradients along the borehole.

Data are obtained using one or more wireline probes with sensors that are lowered inside the casing to each monitoring zone. The probes locate and open the valved ports to measure fluid pressure, collect fluid samples or test hydrogeologic parameters. Multiple probes can be connected in series to provide continuous multilevel data. Software permits

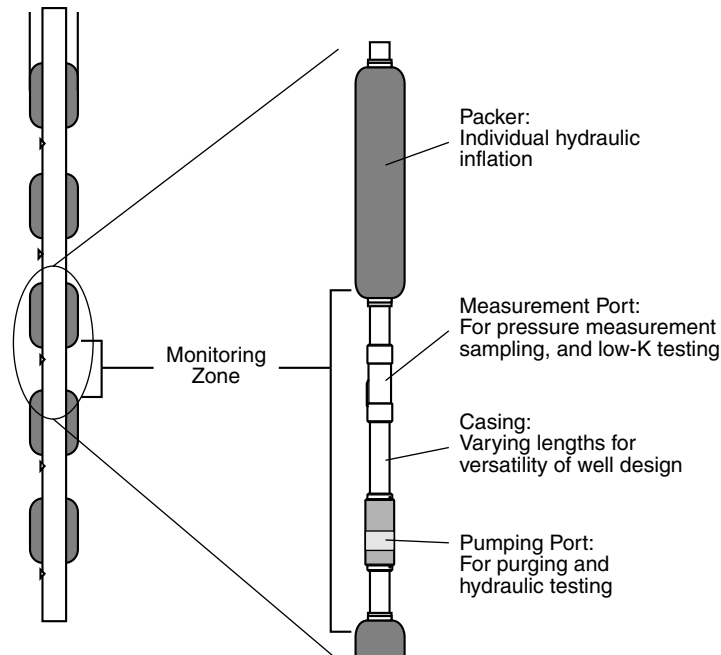

**FIGURE 11.13**  
The Westbay MP<sup>®</sup> system.

notebook computers to interface with the probes and collect data at the surface or from a remote location.

The design of the MP system results in no restriction to the number of zones that can be completed in one borehole, apart from the physical ability to fit the length of the components in the well. The user can have materials on site ahead of time as it is not necessary to know the precise size of the borehole or the desired location of seals and monitoring zones before the equipment is shipped. Users also have access to a wide range of monitoring and testing capabilities such as manual or automated monitoring of pressure (water level), discrete sampling without repeated purging, pulse testing of low-permeability environments, rising- or falling-head (slug) or constant-head hydraulic conductivity testing, vertical interference testing, and cross-well testing (including injection and withdrawal of tracers) (Figure 11.14). Pressure measurements are made under shut-in conditions, making the system responsive to pressure changes. Ground-water samples are collected at formation pressure without repeated purging.

The Westbay system has been in use since 1978 and has been installed in a variety of geologic environments ranging from soft seabed sediments to unconsolidated alluvial deposits, to highly fractured bedrock. Examples of project applications include environmental characterization related to ground-water contamination (e.g., Raven et al., 1992; Gernand et al., 2001; Taraszki et al., 2002) to ground-water resource management (Black et al., 1988), and characterization and monitoring related to nuclear waste repositories (Delouvrier and Delay, 2004). Depths of installation varied from 100 ft (30 m) to greater than 4000 ft (1200 m).

Westbay instrumentation is sold as a complete system and Westbay technicians assist with initial installations and provide on-site training of local personnel. Field quality-control procedures permit the quality of the well installation and the operation of the testing and sampling equipment to be verified at any time.



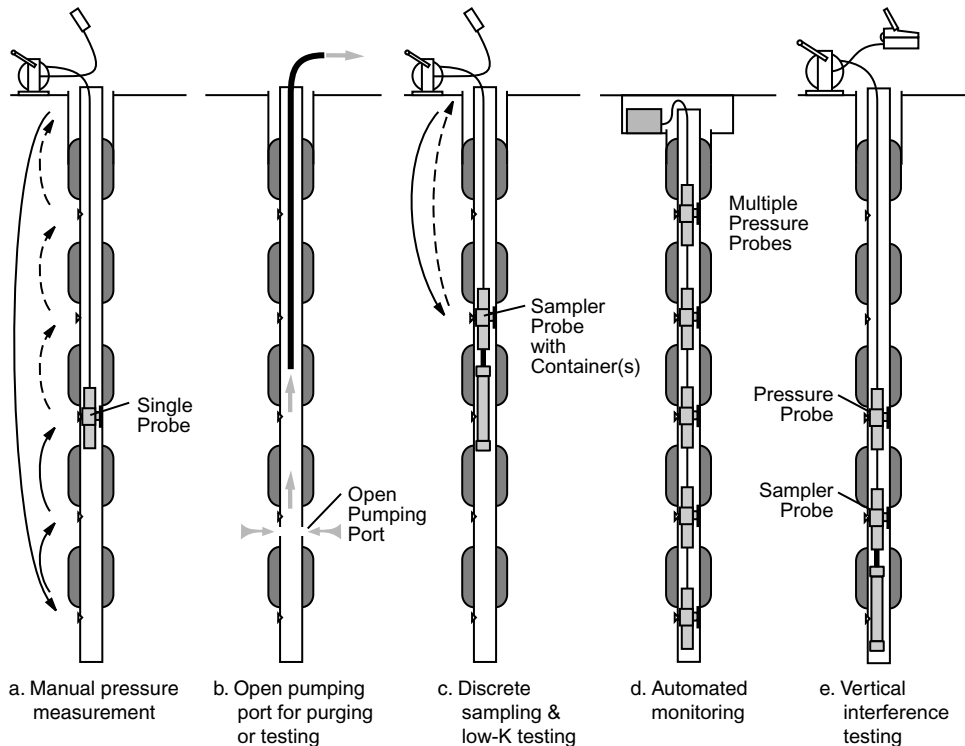

**FIGURE 11.14**

Options for pumping, testing, and monitoring with the Westbay MP system. See text for discussion.

A detailed technical description of the Westbay multilevel monitoring system is presented by Black et al. (1986). Further information about the Westbay multilevel system can be obtained from Westbay Instruments Inc. ([www.westbay.com](http://www.westbay.com)) and from its parent company, Schlumberger Water Services ([www.slb.com/waterservices](http://www.slb.com/waterservices)).

### **Solinst Waterloo System**

The Solinst Waterloo Multilevel ground-water monitoring system is a modular multilevel monitoring system manufactured by Solinst Canada, Ltd. to collect ground-water data from multiple depths within a single drilled borehole. Originally developed by researchers at the University of Waterloo (Cherry and Johnson, 1982), it consists of a series of monitoring ports positioned at specific intervals along 2-in. Schedule 80 PVC casing (Figure 11.15). The ports are typically isolated in the borehole either by in-line packers (permanent or removable), or by alternating layers of sand and bentonite backfilled from the surface. The Solinst Waterloo Multilevel system can also be installed inside multi-screened wells.

The ports and packers are connected to the 2-in. Schedule 80 PVC casing with a special water-tight joint. Monitoring ports are constructed of stainless steel or PVC and have the same water-tight joint to connect with the other system components. Water is added to the inside of the 2-in. PVC casing to overcome buoyancy during installation and to inflate permanent or deflatable packers (if used). A case study in which a removable Waterloo multilevel monitoring system equipped with deflatable packers was used is presented by Sterling et al. (2005).

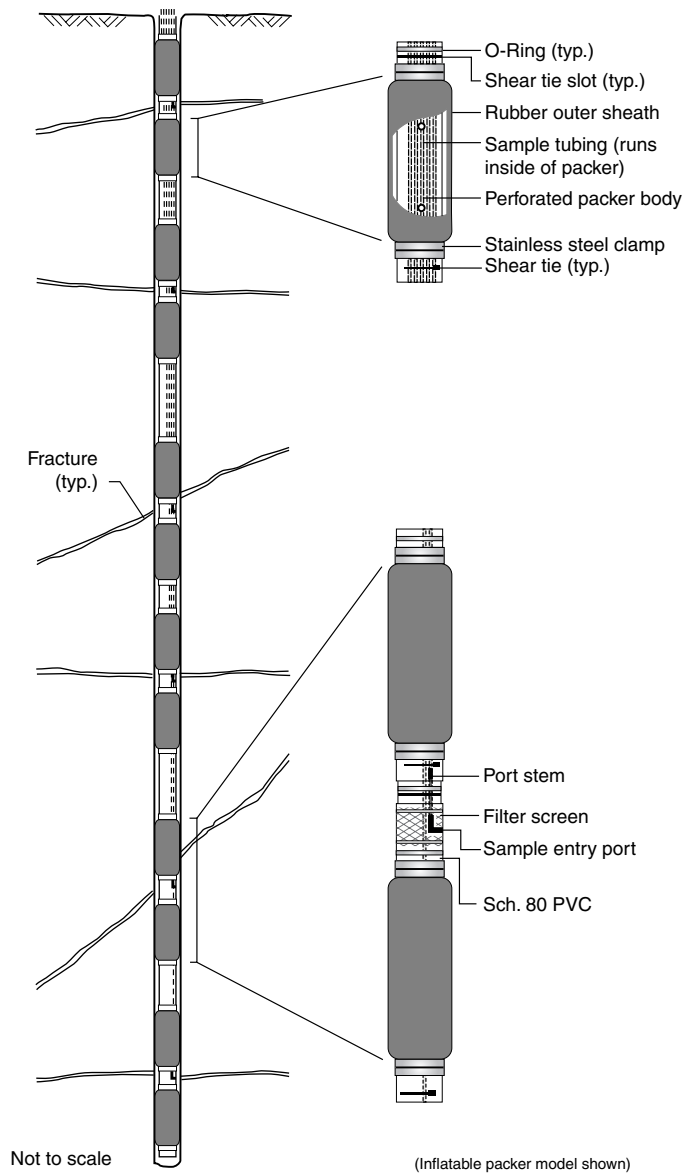

**FIGURE 11.15**

The Solinst Waterloo Multilevel ground-water monitoring system. (Adapted from Cherry and Johnson [1982], With permission.)

Each monitoring port has either a single or dual stem. Each stem is connected to either: (1) an open tube that runs inside the 2-in. PVC casing to the ground surface; (2) a double valve pump; (3) a bladder pump; or (4) a pressure transducer. Pressure transducers can be connected to a data logger for continuous recording of water levels. If open tubes are connected to the port stems, samples can be obtained from inside the tubes using a peristaltic pump, an inertial-lift (i.e., check-valve) pump, or a double-valve gas-drive (positive displacement) pump. Water levels can also be measured in the open tubes using small-diameter water-level meters. Because each port is plumbed to some type of monitoring device, contact between ground water entering the ports and water added to the inside of the 2-in. PVC casing is prevented. If a single stem is used, only one monitoring

device can be used per monitored zone. If dual stems are used, two devices (e.g., a bladder pump and pressure transducer) can be used per zone.

Depending on the monitoring options chosen, the number of zones that can be monitored typically ranges from three to eight, although systems with as many as 15 sampling ports have been installed. Systems installed in fractured rock formations are typically installed in 3- or 4-in.-diameter core holes. A wellhead that facilitates simultaneous purging and sampling of all monitored zones is available. More information about the Solinst Waterloo System is available from Solinst Canada, Ltd. ([www.solinst.com](http://www.solinst.com)).

### ***Solinst CMT System***

The Solinst continuous multichannel tubing (CMT) system is a multilevel ground-water monitoring system that uses custom-extruded flexible 1.6-in. OD multichannel HDPE tubing to monitor as many as seven discrete zones within a single borehole in either unconsolidated sedimentary deposits or bedrock (Figure 11.16). Prior to inserting the tubing in the borehole, ports are created that allow ground water to enter six outer pie-shaped channels (nominal diameter = 0.5 in.) and a central hexagonal center channel (nominal diameter = 0.4 in.) at different depths, facilitating the measurement of depth-discrete piezometric heads and the collection of depth-discrete ground-water samples.

The multichannel tubing can be extruded in lengths up to 300 ft and is shipped in 4-ft-diameter coils. The desired length of tubing, equal to the total depth of the multilevel well, is cut from a coil, and the well is built at the job site based on the hydrogeologic data obtained from the exploratory boring or other methods (e.g., CPT or geophysical data). The tubing is stiff enough to be easily handled, yet light and flexible enough to allow site workers to insert the multilevel well hand-over-hand into the borehole.

Construction of the intake ports and screens is done before the CMT tubing is inserted into the borehole. A small continuous mark along the outside of one of the channels facilitates identification of specific channels. Depth-discrete intake ports are created by cutting ports through the exterior wall of the tubing into each of the channels at the desired depths. Channel 1 ports correspond to the shallowest monitoring interval; channel 2 ports are created further down the tubing (i.e., to monitor a deeper zone), and so forth. The central channel, channel 7, is open to the bottom of the multilevel well. In this way, the ports of the various channels are staggered both vertically and around the perimeter of the multichannel tubing (Figure 11.16). For most of the installations performed as of 2004, an intake interval of approximately 6 in. has been created. The depth interval of the intake ports can be increased by cutting more ports in the tubing.

Stagnant water in the tubing below the intake ports is hydraulically isolated by plugging the channels a few inches below each intake port. This has been done by inserting and expanding a mechanical plug into each channel. Expanding mechanical plugs are also inserted into each of the outer six channels at the very bottom of the tubing. This effectively seals the various channels from just below the intake ports to the bottom of the tubing. Small vent holes are drilled directly beneath the upper polyethylene plugs (i.e., the plugs located just below the intake ports) to allow air to vent out of the sealed channels during installation. The seventh (internal) channel is open to the bottom of the tubing.

Well screens are constructed by wrapping synthetic or stainless steel fabric mesh completely around the tubing in the interval containing the ports. The mesh is secured to the tubing using stainless steel clamps. The size of the mesh openings can be selected based on the grain-size distribution of the particular water-bearing zone being monitored. A guide-point cap containing stainless steel mesh is attached to the bottom of the tubing to enable the central channel to be used as the deepest monitoring zone.

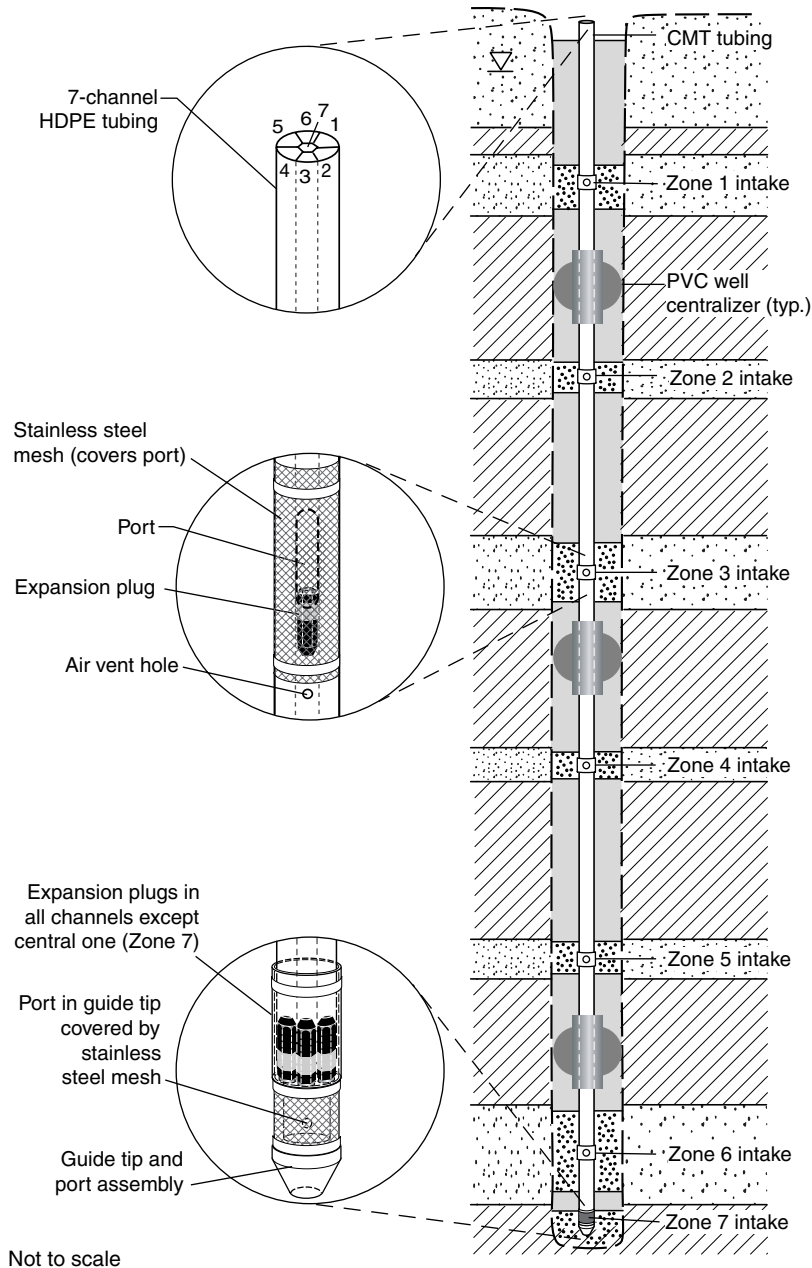

**FIGURE 11.16**  
The Solinst CMT system.

Sand packs and annular seals between the various monitored zones can be installed by backfilling the borehole with alternating layers of sand and bentonite. Inflatable rubber packers for permanent or temporary installations in bedrock aquifers and multiscreen wells are also under development (see Johnson et al., 2002).

Hydraulic heads are measured with conventional waterlevel meters or electronic pressure transducers to generate vertical profiles of hydraulic head. Ground-water

samples are collected using peristaltic pumps, small-diameter bailers, inertial lift pumps, or small-diameter double-valve pumps.

CMT multilevel wells have been installed to depths up to 300 ft below ground surface, although most systems have been installed to depths under 200 ft. These wells have been installed in boreholes created in unconsolidated deposits and bedrock using a wide range of drilling equipment including rotasonic, air rotary, diamond-bit coring, and hollow-stem auger.

A small (1.1 in.) diameter three-channel CMT system has also been developed for installation with DP sampling equipment. Sand pack and bentonite cartridges have also been developed for the three-channel CMT system and are undergoing field trials (unpublished results).

The CMT multilevel monitoring system is described in detail in Einarson and Cherry (2002). A case study in California where CMT wells were installed to depths of 200 ft using sonic drilling equipment is presented by Lewis (2001). The use of CMT wells to assess the fate and transport of MTBE in a chalk aquifer in the U.K. is described by Wealthall et al. (2001). More information about the CMT multilevel monitoring system is available from Solinst Canada, Ltd. ([www.solinst.com](http://www.solinst.com)).

### **Water FLUTe System**

The Water FLUTe (Flexible Liner Underground Technology) is a multilevel ground-water monitoring system that uses a flexible impermeable liner of polyurethane-coated nylon fabric to isolate more than 20 discrete intervals in a single borehole. The system comes in various sizes and can monitor boreholes from 2 to 20 in. in diameter (most installations are in 4- to 10-in. diameter boreholes). The system is custom-made at the factory to the customer's specifications. Sampling ports are created in the liner at the specified depths and small-diameter tubing (0.17 and 0.5 in. OD) is connected to the sampling ports. Pressure transducers and cables (if used) are also installed at the appropriate positions in the liner. The system is pressure tested to 300 psi at the factory. The system is shipped to the job site on a reel and is lowered to the bottom of the borehole by spooling the liner, sampling tubes, transducer cables, etc. off of the reel (Figure 11.17a). The system is shipped "inside out" which facilitates everting the liner and tubes into the borehole. Once the liner is everted, the sampling tubes and cables are inside the liner. The force required to evert the liner comes from hydrostatic pressure that is created by filling the liner with water at the ground surface. Ground water in the borehole is either displaced by the liner or can be pumped out during the installation. The borehole is sealed over its entire length by the pressurized liner. The system is removable by reversing the installation procedure, and may be installed in open boreholes or multiscreened wells.

Samples are collected by applying gas pressure to the sampling tubes, which forces the ground-water sample to the surface (Figure 11.17b). Two check valves are installed in each of the sampling tubes. One of the check valves prevents the water sample from being forced back out of the sampling port when the pressure is applied. The second check valve prevents the ground-water sample from falling back down the sampling line between pressure applications. The system is pumped in three strokes with two purge-pressure applications and one lower-pressure application for sampling. The two purge strokes completely remove all stagnant water from the system. All ports can be purged and sampled simultaneously because the dedicated pump system for each port is essentially the same length regardless of the port depth. Hence, each port produces the same purge and sample volume.

Depth-to-water measurements can be made inside the sampling tubing using small-diameter water-level meters. Optional dedicated pressure transducers facilitate continu-

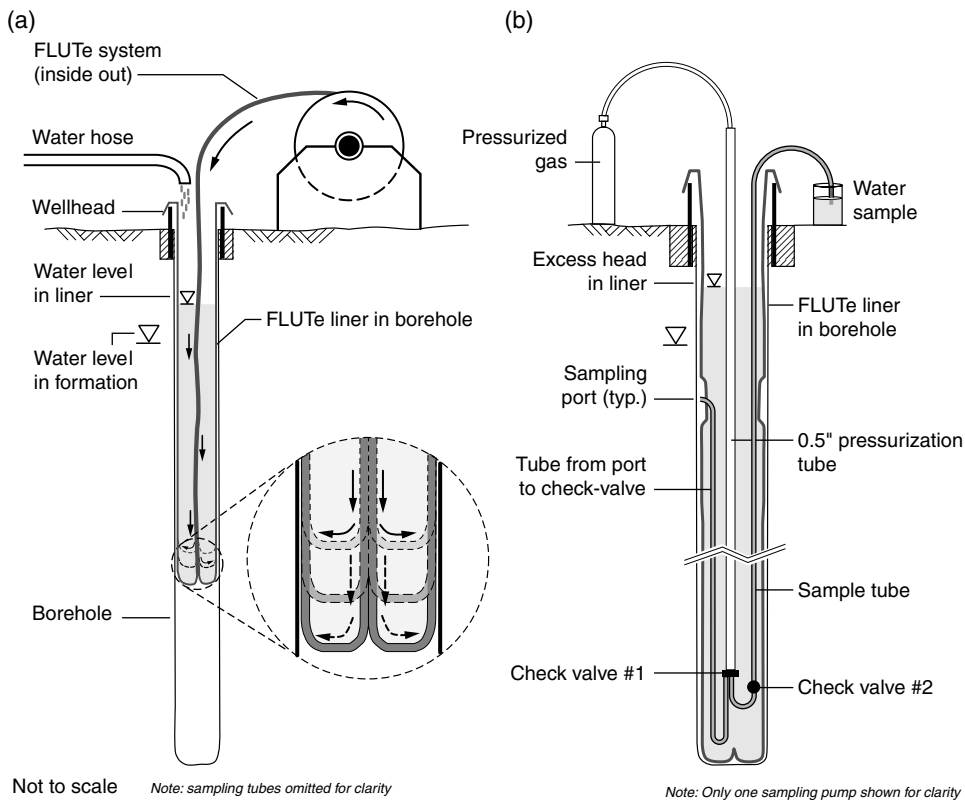

**FIGURE 11.17**

The Water FLUTE system. (a) Installation of a Water FLUTE system; (b) Collecting ground water samples with a Water FLUTE multilevel system.

ous, long-term pressure monitoring. The pressure transducers do not interfere with sampling or manual water-level measurement, or limit the number of ports on the system.

The eversion installation procedure allows installation into nearly horizontal angled holes. A smaller diameter Water FLUTE system has been successfully installed in DP holes with five ports to 60 ft. The seal of the hole is provided by the pressurized liner; no sealing backfill or hole collapse is typically required.

According to the manufacturer, other FLUTE flexible liner systems are used for the following hydrologic applications:

- Sealing of boreholes with blank liners
- Hydraulic conductivity profiling of a borehole while installing a sealing liner
- Multilevel sampling in the vadose zone
- Color reactive mapping of LNAPL and DNAPL in boreholes and cores
- Liner augmentation of horizontal drilling
- Towing of logging tools and cameras into boreholes

More information about the FLUTE system can be obtained from Flexible Liner Underground Technologies, Ltd. ([www.flut.com](http://www.flut.com)).

---

## References

- Akindunni, F.F., R.W. Gillham, B. Conant, Jr., and T. Franz, Modeling of contaminant movement near pumping wells: saturated-unsaturated flow with particle tracking, *Ground Water*, 33(2), 264–274, 1995.
- Aller, L., T.W. Bennett, G. Hackett, R.J. Petty, J.H. Lehr, H. Sedoris, D.M. Nielsen, and J.E. Denne, Handbook of Suggested Practices for the Design and Installation of Ground-Water Monitoring Wells, EPA/600/4-89/034, U.S. Environmental Protection Agency, Las Vegas, NV, Cooperative Agreement CR-812350-01, 1989, 245 pp.
- Barrow, J.C., The resonant sonic drilling method: An innovative technology for environmental restoration programs, *Ground Water Monitoring and Remediation*, 14(2), 153–160, 1994.
- Black, W.H., H.R. Smith, and F.D. Patton, Multiple-Level Ground-Water Monitoring With the MP System, Proceedings of the Conference on Surface and Borehole Geophysical Methods and Ground Water Instrumentation, National Water Well Association, Dublin, OH, 1986, pp. 41–60.
- Black, W.H., J.A. Goodrich, and F.D. Patton, Ground-Water Monitoring for Resource Management, paper presented at ASCE International Symposium on Artificial Recharge of Ground Water, Anaheim, CA, August 21–28, 1988, pp. 1–7.
- Borden, R.C., R.A. Daniel, L.E.I. LeBrun, and C.W. Davis, Intrinsic biodegradation of MTBE and BTEX in a gasoline-contaminated aquifer, *Water Resources Research*, 33(5), 1105–1115, 1997.
- California Department of Water Resources, California Water Well Standards, Bulletin 74-90, California Department of Water Resources, Sacramento, CA, 1990.
- Cherry, J.A., personal communication, 2004.
- Cherry, J.A. and P.E. Johnson, A multi-level device for monitoring in fractured rock, *Ground-Water Monitoring Review*, 2(3), 41–44, 1982.
- Cherry, J.A., J.F. Barker, P.M. Buszka, J.P. Hewetson, and C.I. Mayfield, Contaminant Occurrence in an Unconfined Sand Aquifer at a Municipal Landfill, Proceedings of the Fourth Annual Madison Conference on Applied Research and Practice on Municipal and Industrial Waste, University of Wisconsin, Madison, Wisconsin, 1981, pp. 1–19.
- Cherry, J.A., R.W. Gillham, E.G. Anderson, and P.E. Johnson, Migration of contaminants in ground water at a landfill: a case study 2. Ground-water monitoring devices, *Journal of Hydrology*, 63, 31–49, 1983.
- Chiang, C., G. Raven, and C. Dawson, The relationship between monitoring well and aquifer solute concentrations, *Ground Water*, 33(5), 718–726, 1995.
- Church, P.E. and G.E. Granato, Bias in ground-water data caused by well-bore flow in long-screen wells, *Ground Water*, 34(2), 262–273, 1996.
- Conant, B., Jr., F.F. Akindunni, and R.W. Gillham, Effect of well-screen placement on recovery of stratified contaminants, *Ground Water*, 33(3), 445–457, 1995.
- D'Astous, A.Y., W.W. Ruland, R.G. Bruce, J.A. Cherry, and R.W. Gillham, Fracture effects in the shallow ground water zone in weathered Sarnia-Area Clay, *Canadian Geotechnical Journal*, 26, 43–56, 1989.
- Delouvrier, J. and J. Delay, Multi-Level Ground-Water Pressure Monitoring at the Meuse/Haute-Marne Underground Research Laboratory, France, Proceedings of EurEnGeo 2004, Liege, Belgium, May, 2004, pp. 377–384.
- Devlin, J.F., M.L. McMaster, D.J. Katic, and J.F. Barker, 2001, Evaluating Natural Attenuation in a Controlled Field Experiment by Mass Balances, Flux Fences and Snapshots: A Comparison of Results, Paper presented at Ground Water Quality 2001, Sheffield, U.K., July 18–21, 2001, pp. 282–285.
- Drost, W., D. Klotz, A. Koch, H. Moser, F. Neumaier, and W. Rauert, 1968, Point dilution methods of investigating ground water flow by means of radioisotopes, *Water Resources Research*, 4(1), 125–146, 1968.
- Einarson, M.D., EnviroCore: A new dual-tube direct push system for collecting continuous soil cores, *Proceedings of the Ninth National Outdoor Action Conference*, National Ground Water Association, Dublin, OH, 1995, pp. 419–433.

- Einarson, M.D. and J.A. Cherry, A new multi-level ground-water monitoring system utilizing multi-channel tubing, *Ground-Water Monitoring and Remediation*, 22(4), 52–65, 2002.
- Einarson, M.D. and D.M. Mackay, Predicting impacts of ground-water contamination, *Environmental Science & Technology*, 35(3), 66A–73A, 2001.
- Elci, A., F. Molz, and W.R. Waldrop, Implications of observed and simulated ambient flow in monitoring wells, *Ground Water*, 39(6), 853–862, 2001.
- Elci, A., G.P. Flach, and F. Molz, Detrimental effects of natural vertical head gradients on chemical and water-level measurements in observation wells: identification and control, *Journal of Contaminant Hydrology*, 28, 70–81, 2003.
- Feenstra, S., J.A. Cherry, and B.L. Parker, Conceptual models for the behavior of nonaqueous phase liquids (DNAPLs) in the subsurface, in *Dense Chlorinated Solvents and Other DNAPLs in Ground Water*, James F. Pankow and John A. Cherry, Eds., Waterloo Press, Waterloo, Ontario, Canada, pp. 53–88.
- Foote, G.R., N.T. Bice, L.D. Rowles, and J.D. Gallinatti, TCE and flow monitoring methods using an existing water supply well, *Journal of Environmental Engineering*, June, 564–571, 1998.
- Freeze, R.A. and J.A. Cherry, *Groundwater*, Prentice-Hall, Englewood Cliffs, NJ, 1979, 604 pp.
- Gernand, J., B. Rundell, and C. Yen, Practical Bedrock Aquifer Characterization Using Borehole Geophysics and Multilevel Wells, Practice Periodical of Hazardous, Toxic, and Radioactive Waste Management, 2001, pp. 111–118.
- Gibs, J., G.A. Brown, K.S. Turner, C.L. MacLeod, J.C. Jelinski, and S.A. Koehnlein, Effects of small-scale vertical variations in well-screen inflow rates and concentrations of organic compounds on the collection of representative ground-water quality samples, *Ground Water*, 31(2), 201–208, 1993.
- Gossell, M.A., T. Nishikawa, R.T. Hanson, J.A. Izbicki, M.A. Tabidian, and K. Bertine, Application of flowmeter and depth-dependent water quality data for improved production well construction, *Ground Water*, 37(5), 729–735, 1999.
- Guilbeault, M.A., B.L. Parker, and J.A. Cherry, Mass flux distributions from DNAPL Zones in Sandy Aquifers, *Ground Water*, 43(1), 70–86, 2005.
- Haas, J.E. and C. Sosik, Smart Pump-and-Treat Strategy for MTBE Impacting a Public Water Supply Well Field, Proceedings of the Fourteenth Annual Conference on Contaminated Soils, AEHS, Amherst, MA, 1998, pp. 1–31.
- Hanson, R.T., M.W. Newhouse, C.M. Wentworth, C.F. Williams, T.E. Noce, and M.J. Bennett, Santa Clara Valley Water District Multi-Aquifer Monitoring Well Site, Coyote Creek Outdoor Classroom, San Jose, California, U.S. Geological Survey, Open-File Report 02-369, 2002, 4 pp.
- Hutchins, S.R. and S.D. Acree, Ground-water sampling bias observed in shallow conventional wells, *Ground-Water Monitoring and Remediation*, 20(1), 86–93, 2000.
- Jansen, J., Geophysical well logging and discrete water sampling methods to identify sources of elevated barium in a water well in Northern Illinois, Proceedings of the Symposium on the Application of Geophysics to Environmental and Engineering Problems, Society for Environmental and Engineering Geophysics, Denver, CO, 1998, pp. 315–322.
- Johnson, T.L., A comparison of well nests vs. single-well completions; *Ground-Water Monitoring Review*, 3(1), 76–78, 1983.
- Johnson, C.D., F.P. Haeni, and J.W. Lane, Importance of discrete-zone monitoring systems in fractured-bedrock wells — a case study from the University of Connecticut Landfill, Storrs, Connecticut, Proceedings of the Symposium on the Application of Geophysics to Engineering and Environmental Problems, Society for Environmental and Engineering Geophysics, Denver, CO, 2002, pp. 1–4.
- Kao, C.M. and Y.S. Wang, Field investigation of natural attenuation and intrinsic biodegradation rates at an underground storage tank site, *Environmental Geology*, 40(4–5), 622–631, 2001.
- Lewis, M., Installing continuous multi-chamber tubing using sonic drilling, *Water Well Journal*, July, 16–17, 2001, pp. 16–17.
- MacFarlane, D.S., J.A. Cherry, R.W. Gillham, and E.A. Sudicky, Migration of contaminants in ground water at a landfill: a case study 1. ground water flow and plume delineation, *Journal of Hydrology*, 63, 1–29, 1983.



- Mackay, D.M., J.A. Cherry, D.L. Freyberg, and P.V. Roberts, A natural gradient experiment on solute transport in a sand aquifer 1. Approach and overview of plume movement, *Water Resources Research*, 22(13), 2017–2029, 1986.
- Martin-Hayden, J.M., Controlled laboratory investigations of wellbore concentration response to pumping, *Ground Water*, 38(1), 121–128, 2000a.
- Martin-Hayden, J.M., Sample concentration response to laminar wellbore flow: implications to ground-water data variability, *Ground Water*, 38(1), 12–19, 2000b.
- Martin-Hayden, J.M. and G.A. Robbins, Plume distortion and apparent attenuation due to concentration averaging in monitoring wells, *Ground Water*, 35(2), 339–346, 1997.
- Martin-Hayden, J.M., G.A. Robbins, and R.D. Bristol, Mass-balance evaluation of monitoring well purging, Part II. Field tests at a gasoline contamination site, *Journal of Contaminant Hydrology*, 8, 225–241, 1991.
- McIlvride, W.A. and B.M. Rector, Comparison of short and long-screened wells in alluvial sediments, Proceedings of the Second Outdoor Action Conference, National Ground-Water Association, Dublin, OH, 1988, pp. 375–390.
- Nakamoto, D.B., F.R. McLaren, and P.J. Philips, Multiple completion monitor wells, *Ground-Water Monitoring Review*, 6(2), 50–55, 1986.
- National Research Council, *Alternatives for Ground Water Cleanup*, National Research Council, Washington, DC, National Academy Press, 1994, 314 pp.
- Newell, C.J., J.A. Conner, and D.L. Rowen, Ground Water Remediation Strategies Tool, Publication Number 4730, American Petroleum Institute, Washington, DC, 2003, 80 pp.
- Pankow, J.F. and J.A. Cherry, *Dense Chlorinated Solvents and other DNAPLs in Groundwater*, Waterloo Press, Waterloo, Ontario, Canada, 1996, 522 pp.
- Parker, L.V. and C.H. Clark, Study of Five Discrete Interval-Type Ground Water Sampling Devices, ERDC/CRREL Publication #TR-02–12, U.S. Army Corps of Engineers, Hanover, NH, 2002, 49 pp.
- Pitkin, S.E., J.A. Cherry, R.A. Ingleton, and M. Broholm, Field demonstrations using the Waterloo ground-water profiler, *Ground-Water Monitoring and Remediation*, 19(2), 122–131, 1999.
- Puls, R.W. and C.J. Paul, Multi-layer sampling in conventional monitoring wells for improved estimation of vertical contaminant distribution and mass, *Journal of Contaminant Hydrology*, 25(1), 85–111, 1997.
- Raven, K.G., K.S. Novakowski, R.M. Yager, and R.J. Heystee, Supernormal fluid pressures in sedimentary rocks of southern Ontario–Western New York State, *Canadian Geotechnical Journal*, 29, 80–93, 1992.
- Reilly, T.E. and J. Gibs, Effects of physical and chemical heterogeneity on water quality samples obtained from wells, *Ground Water*, 31(5), 805–813, 1993.
- Reilly, T.E. and D.R. LeBlanc, Experimental evaluation of factors affecting temporal variability of water samples obtained from long-screened wells, *Ground Water*, 36(4), 566–576, 1998.
- Reilly, T.E., O.L. Franke, and G.D. Bennett, Bias in ground-water samples caused by well-bore flow, *Journal of Hydrologic Engineering*, 115, 270–276, 1989.
- Reinhard, M., N.L. Goodman, and J.F. Barker, Occurrence and distribution of organic chemicals in two landfill leachate plumes, *Environmental Science & Technology*, 18, 953–961, 1984.
- Rivett, M.O., Soil-gas signatures from volatile chlorinated solvents: borden field experiments, *Ground Water*, 33(1), 84–98, 1995.
- Robbins, G.A., Influence of purged and partially penetrating monitoring wells on contaminant detection, mapping and modeling, *Ground Water*, 27(2), 155–162, 1989.
- Robbins, G.A. and J.M. Martin-Hayden, Mass-balance evaluation of monitoring well purging, Part I. Theoretical models and implications for representative sampling, *Journal of Contaminant Hydrology*, 8, 203–224, 1991.
- Robertson, W.D., J.A. Cherry, and E.A. Sudicky, Ground-water contamination from two small septic systems on sand aquifers, *Ground Water*, 29(1), 82–92, 1991.
- Ronen, D., M. Magaritz, and I. Levy, An in-situ multilevel sampler for preventive monitoring and study of hydrochemical profiles in aquifers, *Ground-Water Monitoring Review*, 7(4), 69–74, 1987.
- Semprini, L., P.K. Kitanidis, D.H. Kampbell, and J.T. Wilson, Anaerobic transformation of chlorinated aliphatic hydrocarbons in a sand aquifer based on spatial chemical distributions, *Water Resources Research*, 31(4), 1051–1062, 1995.

- Smith, R.L., R.W. Harvey, J.H. Duff, and D.R. LeBlanc, Importance of Close-Interval Vertical Sampling in Delineating Chemical and Microbiological Gradients in Ground-Water Studies, U.S. Geological Survey, Open File Report 87-109, 1987, pp. B33–B35.
- State of Washington, Washington State Administrative Code (WAC), 173-160-420(3), State of Washington, 2004.
- Sterling, S.N., B.L. Parker, J.A. Cherry, J.H. Williams, J.W. Lane, and F.P. Haeni, Vertical cross contamination of TCE in a borehole in fractured sandstone, *Ground Water*, in press.
- Sukop, M.C., Estimation of vertical concentration profiles from existing wells. *Ground Water*, 38(6), 836–841, 2000.
- Taraszki, M., C. Merrey, and G. Mitchell, Ground-water quality evaluation using Westbay monitoring well systems, Former Fort Ord, California, Proceedings of the 2002 National Monitoring Conference, National Water Quality Monitoring Council, Washington, DC, 2002.
- U.S. Army Corps of Engineers, Monitoring Well Design, Installation and Documentation at Hazardous, Toxic, and Radioactive Waste Sites, Engineer Manual 1110–1-4000, U.S. Army Corps of Engineers, Washington, DC, 1998, 69 pp.
- U.S. EPA, RCRA Ground-Water Monitoring: Draft Technical Guidance. Office of Solid Waste, U.S. Environmental Protection Agency, November 1992. Update to Chapter 11 of SW-846 (Revision 0, September 1986) and the Technical Enforcement Guidance Document (TEGD), 1992.
- U.S. EPA, Expedited Site Assessment Tools for Underground Storage Tank Sites — A Guide for Regulators, EPA/510-B-97-001, U.S. Environmental Protection Agency, Washington, DC, 1997.
- U.S. EPA, Monitored Natural Attenuation for Ground Water, Seminar Notes, EPA/625/K-98/00, U.S. Government Printing Office, Washington, DC, 1998.
- van der Kamp, G., L.D. Luba, J.A. Cherry, and H. Maathuis, Field study of a long and very narrow contaminant plume, *Ground Water*, 32(6), 1008–1016, 1994.
- Varljen, M.D., M.J. Barcelona, J. Obereiner, and D. Kaminski, Numerical simulations to assess the monitoring zone achieved during low-flow purging and sampling, *Ground-Water Monitoring and Remediation*, in press.
- Vroblesky, D.A. and W.T. Hyde, Diffusion samplers as an inexpensive approach to monitoring VOCs in ground water, *Ground-Water Monitoring and Remediation*, 17(3), 177–184, 1997.
- Vroblesky, D.A., L.C. Rhodes, J.F. Robertson, and J.A. Harrigan, Locating VOC contamination in a fractured-rock aquifer at the ground-water/surface-water interface using passive vapor collectors, *Ground Water*, 34(2), 223–230, 1996.
- Wealthall, G.P., S.F. Thornton, and D.N. Lerner, 2001, Assessing the Transport and Fate of MTBE-Amended Petroleum Hydrocarbons in the UK Chalk Aquifer, paper presented at Ground Water Quality 2001, *Third International Conference on Ground-Water Quality*, University of Sheffield, U.K., June 18–21, 2001, pp. 369–374.