

Single Point Packer: Installation & Inflation

Model 800 Pneumatic Packers are inflated with air via 1/8" (3.2 mm) O.D. tubing extending from the packer to the surface. A manual hand pump with a gauge may be used to inflate the packer. Please read through these instructions fully before proceeding.

Note: Figures A and B (found overleaf) illustrate centralizer installation for both Single Point and Straddle Packers. For packer specifications, borehole sizes and required inflation pressures, please refer to the charts below.

1. Cut an appropriate length of 1/8" (3.2 mm) O.D. tubing to extend from the packer to the surface. This tubing must extend to the surface with enough slack to allow ease of inflation.
2. Push the inflation valve onto the top end of the tubing and connect the other end of the inflation tube to the packer.
3. For proper connection of tubing to compression fittings, simply push the tubing into the fittings until it "bottoms" and tighten the nut 3/4 turn past finger tight. Check the connection by pulling firmly on the tubing. It should not pull out of the fitting.
4. A safety cable should be attached to the eyebolt on the packer to allow securing at surface. The Solinst Tag Line can be used for this purpose. (See Model 103 Data Sheet.)
5. The system is now complete and should be installed by connecting the appropriate riser pipe and lowering the system into the well. Hang the riser pipe such that the packer is suspended at the appropriate depth.

Note: All Model 800 Packers are designed for short term applications. However, if longer continuous usage is necessary, weekly monitoring of target inflation pressure and packer seal will be required.

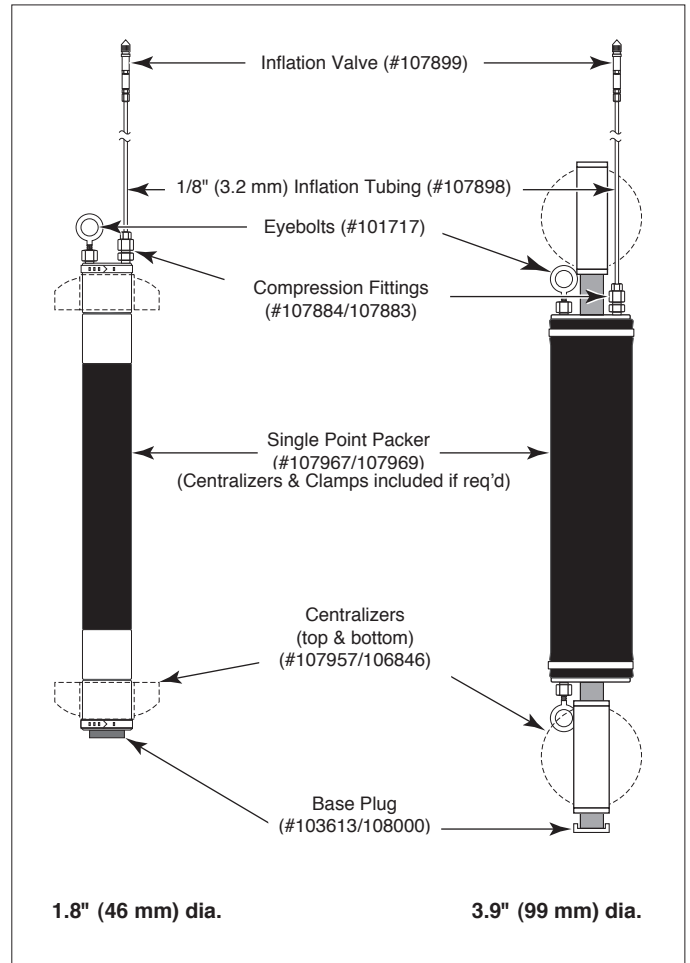

Standard Single Point Packer Setup with Inflation Lines

800 Packer Specifications (Single Point and Straddle Packers)

Packer	1.8" O.D. (46 mm)	3.9" O.D. (99 mm)
Well Size	1.9 - 2.4" (48 - 61 mm)	4.0 - 4.4" (102 - 112 mm)
Inflation Pressure	20 - 30 psi, 140 - 205 kPa	20 psi, 140 kPa
With Centralizers		
Well Size	2.5 - 3.5" (63 - 89 mm)	4.5 - 5.0" (114 - 127 mm)
Inflation Pressure	35 - 40 psi, 240 - 275 kPa	25 - 30 psi, 170 - 205 kPa
Notes: 1. <u>Inflation pressures</u> must be added to hydrostatic pressure at the packer location. 2. <u>Maximum depth</u> from surface = 275 ft (84 m) 3. <u>Maximum submergence</u> = 150 ft (46 m) 4. <u>Maximum pressure</u> for 1.8" (46 mm) packer, = 50 psi or 345 kPa over hydrostatic pressure. Maximum pressure for 3.9" (99 mm) packers = 30 psi or 205 kPa over hydrostatic pressure. (1 ft water = 0.43 psi, 1 m water = 9.8 kPa) eg: Required pressure for: Packer placed 100 ft (30 m) below water • 1.8" packer in 2" well: 20 psi minimum + (100 ft x 0.43 psi) = 20 + 43 = 63 psi. (46 mm packer: 140 kPa minimum + (30 x 9.8 kPa) = 140 + 294 = 434 kPa)		

Specifications		
Borehole Size	1.9 - 2.4" (48 - 61 mm)	4.0 - 4.4" (102 - 112 mm)
-with centralizers	2.5 - 3.5" (63 - 89 mm)	4.5 - 5.0" (114 - 127 mm)
Packer Size OD	1.8" (46 mm)	3.9" (99 mm)
Access ID	1/2" (12.7 mm)	1" (25.4 mm)
Gland Length	23" (584 mm)	30" (762 mm)
Overall Length	29" (737 mm)	36" (914.4 mm)
-with centralizers	29" (737 mm)	44" (1117.6 mm)
Pipe Fittings	1/2" NPT - Female	1" NPT - Male
-with centralizers	1/2" NPT - Female	1" NPT - Female

Straddle Packer: Installation & Inflation

Model 800 Pneumatic Packers are inflated with air via 1/8" (3.2 mm) O.D. tubing extending from the packer to the surface. A hand pump with a gauge may be used to inflate the packer. Please read through these instructions fully before proceeding.

Straddle Packer: Assembly & Tubing Connection

1. To assemble the Straddle Packer system, connect the lower and upper packers with a suitable length of screen or perforated pipe (1/2" NPT for 1.8" (46 mm) or 1" NPT for 3.9" (99 mm) packers).

To connect 3.9" (99 mm) packers, you will also need to use a PVC bushing, and the NPTF coupling that comes with the perforated straddle pipe (see diagram).

2. Attach a length of 1/8" (3.2 mm) inflation line between the top of the lower packer and the bottom of the upper packer.
3. Cut an appropriate length of 1/8" (3.2 mm) O.D. tubing to extend from the top packer to the surface with enough slack to allow ease of inflation.
4. Push the inflation valve onto the top end of the tubing and connect the other end of the inflation tube to the packer. For proper connection of tubing to compression fittings, simply push the tubing into the fitting until it "bottoms" and tighten the nut 3/4 turn past finger tight. Check the connection by pulling firmly on the tubing. It should not pull out of the fitting.
5. A safety cable should be attached to the eyebolt on the packer to allow securing at surface, and between each packer. The Solinst Tag Line can be used for this purpose. (See Model 103 Data Sheet.)
6. The system is now complete and should be installed by connecting the appropriate riser pipe and lowering the system into the well.
7. Hang the riser pipe such that the packer is suspended at the appropriate depth.

Notes: 1. Figures A and B illustrate centralizer installation for both Single Point and Straddle Packers. For packer specifications, borehole sizes and required inflation pressures, please refer to the charts overleaf.

2. The lower packer of the Straddle Packer system has only one inflation line fitting.

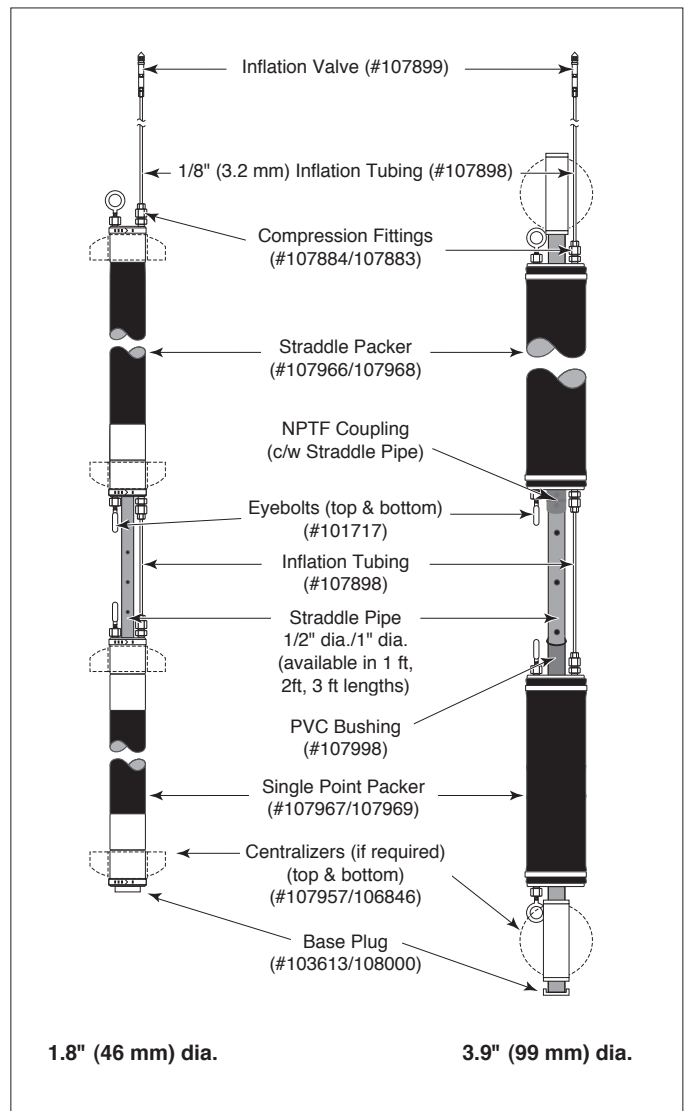

Standard Straddle Packer Setup with Inflation Lines

800 Packer Centralizer Installation (Single Point and Straddle Packers)

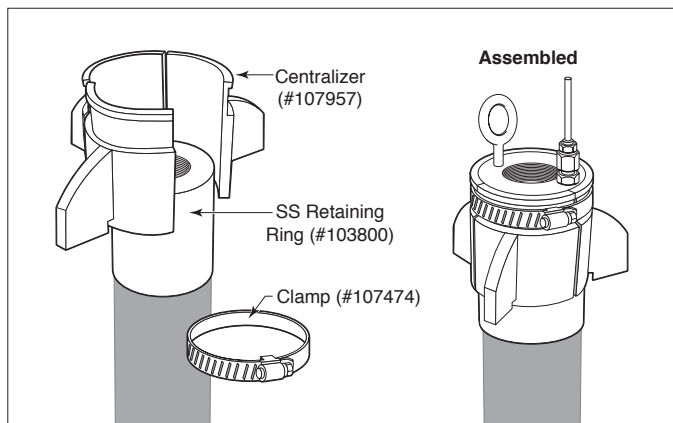

Figure A - 1.8" (46 mm) Centralizer Assembly

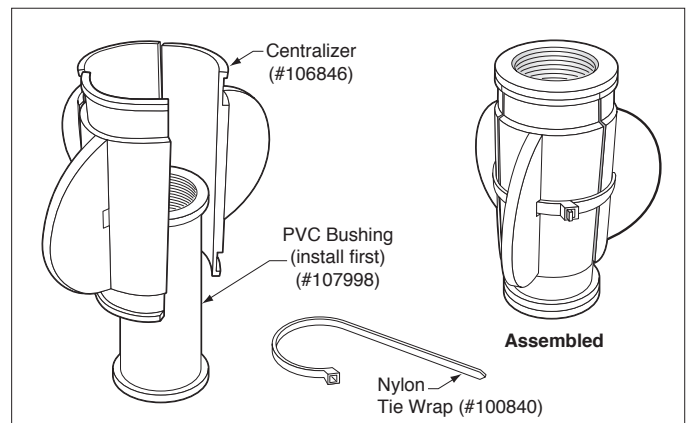

Figure B - 3.9" (99 mm) Centralizer Assembly